

RED RIVER MACHINERY
1-800-229-0759
<https://www.redrivermachinery.com>



*The Betenbender
Family of American
Press Brakes and Shears*

SHEAR

OPERATOR'S MANUAL / PARTS CATALOG

for the Installation, Operation and Maintenance of the Betenbender Shear

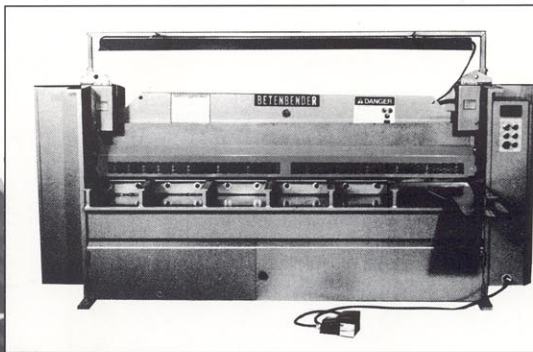
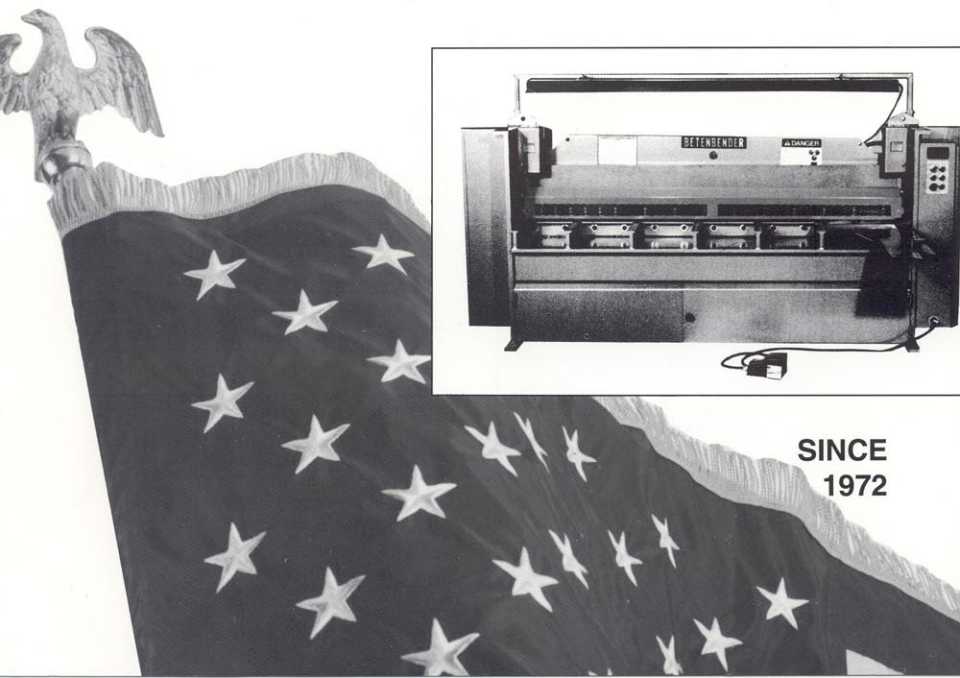

**SINCE
1972**

TABLE OF CONTENTS

SECTION 1:	DECALS	5-11
	INSTALLATION	12
	CLEANING	15
	CONNECTING ELECTRICAL SERVICE	15
	HYDRAULIC OIL	18
	INITIAL STARTING PROCEDURE	15
	LEVELING	15
	LUBRICATION	16
	RECEIVING	12
	RIGGING AND HANDLING	13
	WARRANTY	1
	SAFETY INSTRUCTIONS	14
	SETTING MICRO SWITCHES	22
SECTION 2:	OPERATION/SELECTION OF OPERATING MODE	23
	GAGING	24
	BACKGAUGE	24
	CHECKING SQUARENESS	26
	EXTENSION SQUARING GAUGE	24
	LIGHT BEAM GAUGE	24
	SETTING BLADES	
	DETERMINE BLADE CLEARANCE	27
	SETTING BLADE CLEARANCE	28
	MAINTENANCE OF BLADE	30
	SHEARING	
	ACCURATE SHEARING	31
	SHEARING NARROW STRIPS	32
	WHERE TO CUT	32
	CAMBER, CURL AND BOW	32
SECTION 3:	MAINTENANCE	
	BACKGAUGE BAR ADJUSTMENT	
	BLADES	
	CARE OF BLADES	30
	CHANGING BLADES	35
	GRADES OF BLADES	37
	REGRINDING BLADES	39
	REORDERING BLADES	37
	HYDRAULIC COMPONENTS	34
	HOLDDOWN CYLINDERS	17
	MAIN HYDRAULIC CYLINDERS	34
	ELECTRICAL COMPONENTS	34
	PREVENTATIVE MAINTENANCE CHECKLIST	33
	MILD STEEL SHEARING CAPACITIES	38
	TROUBLE SHOOTING	40
	ELECTRICAL SCHEMATICS	46-47
	HYDRAULIC SCHEMATICS	45
	MSD SHEETS	48-53

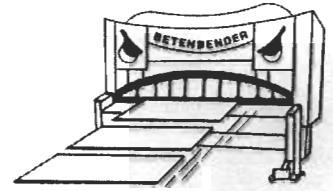

MANUFACTURERS WARRANTY

At BETENBENDER MANUFACTURING, INC. we guarantee our product against failure caused by defective workmanship or material which occurs after the product is properly installed within product specifications and during normal use and operation for the period of one year, and that the frame shall be free of manufacturer defect for a period of five years.

We will replace all parts, which our inspection shows to be defective, for one year after delivery date, but not installation or other charges. *Written permission* for warranty returns must be obtained before shipment. Ship all returns freight prepaid and include a complete explanation of the problem.

The only warranty extended to the buyer by BETENBENDER MFG., INC. is the above expressed warranty and there are no other warranties, expressed or implied, of merchantability, fitness for a particular purpose, or otherwise which extend beyond the face hereof. BETENBENDER MFG., INC. shall in no event be liable for labor or freight charges or for consequential or incidental damages including, but not limited to, injury to the person or property of buyer or any others, machine down time, and losses or expenses incurred by buyer, arising from the use of this equipment or from this agreement. This warranty constitutes the entire warranty of the manufacturer, BETENBENDER MFG., INC. and no oral representations; warranties or guarantee by any agent of manufacturer or seller shall be binding on BETENBENDER MFG., INC. and no part of this warranty may be modified or extended by, except by written agreement executed by BETENBENDER MFG., INC.

It is our policy to improve its products whenever possible and practical to do so. We reserve the right to make changes, improvements and modifications at any time without incurring the obligation to make such changes, improvements and modifications on any equipment sold previously.

Betenbender

MODEL WEIGHTS*

10 ga.	5-125	4,800
	6-125	6,500
	8-125	6,800
	10-125	8,900
	12-125	13,000

3/16"	4-1875	4,800
	6-1875	6,700
	8-1875	7,000
	10-1875	9,100
	12-1875	15,000
	14-1875	

1/4"	4-250	7,500
	6-250	8,400
	8-250	9,800
	10-250	12,500
	12-250	14,000

3/8"	4-375	8,700
	6-375	9,800
	8-375	15,200
	10-375	21,000
	12-375	24,000

1/2"	4-500	9,000
	6-500	11,340
	8-500	15,000
	10-500	26,000
	12-500	27,300

5/8"	10-625	28,000
	12-625	32,000

3/4"	4-750	15,700
	6-750	
	8-750	27,000
	10-750	31,000

***Weights may vary according to options included**

Please have this information handy when calling our service department.

Model _____

Serial # _____

Date of Purchase _____

CAPACITIES

Length of Cut _____

Capacity of cut (mild steel, 80,000 PSI) _____

Length of Squaring Arm _____

Backgauge Depth: **Minimum** _____
Maximum _____

Line Voltage _____

Control Voltage _____

Motor HP _____

Hydraulic Oil Capacity _____
Type _____

Hydraulic Pressure at Holddowns, 300 PSI + _____

Hydraulic Pressure at Shear Cylinders, 2500 PSI _____

Weight _____

GUIDELINES FOR CONTROLS OF HAZARDOUS ENERGY LOCKOUT/TAGOUT ON THE BETENBENDER SHEAR/PRESS BRAKE

These guidelines address the servicing and maintenance of shear/press brakes in which unexpected energizing or start-up of the machine or release of stored energy could cause injury to employees.

Affected employees are those whose job requires him/her to operate or use a machine or equipment on which servicing or maintenance is being performed under lockout/tagout, or whose job requires him/her to work in an area which such servicing or maintenance is being performed.

MECHANICAL SHUTDOWN: Lowering ram into bottom of stroke, blocking ram at top of stroke, pinning ram at top of stroke, and chaining ram at top of stroke, are the common methods of controlling the release of stored energy in the system.

ELECTRICAL SHUTDOWN: Turn off the electrical power at the main or "Start" switch is the normal shutdown before lockout. Then go to main energy isolating device, and ensure that the energy isolating device, and the shear/press brake being controlled, cannot be operated until the lockout device is removed. Place lockout at these points.

A prominent warning device such as a tag and a means of attachment which can be securely fastened to the energy isolating device and the shear/press brake being controlled. Tagout devices shall warn against hazardous conditions if the shear/press brake is energized and shall include a legend such as the following: **DO NOT START, DO NOT OPEN, DO NOT CLOSE, DO NOT ENERGIZE or DO NOT OPERATE.**

Following the application of lockout/tagout devices to energy isolating devices, all potential hazardous stored or residual energy shall be relieved, disconnected, restrained, and otherwise rendered safe.

Other potential energy sources to be concerned with are:

- Other electrical hazards besides the main power sources?
- Battery back-ups? (NC/CNC gauging)
- Pneumatics?
- Capacitors?
- Thermal energy of 113° F?
- Do they create a hazard?
- Can they be locked out?
- Are there means to control the release of the stored energy?
- Must employee's work in close proximity of this heat?
- Are means available to bring the temperature within acceptable temperature range or is Personal Protective equipment available for use?

DURING LOCKOUT/RETURN TO SERVICE: Periodic inspection shall be performed by an authorized employee other than the person utilizing the energy control procedure being inspected during the time of lockout/tagout.

After completion of work on the shear/press brake, all affected employees shall be notified by an authorized employee of the application and removal of lockout/tagout devices. Notification shall be given before controls are applied and after they are removed from the shear/press brake.

Before lockout/tagout devices are removed and energy is restored to the shear/press brake, authorized employees shall ensure the following: Work area is inspected to ensure that nonessential items have been removed and to ensure that shear/press brake components are operationally intact. The work area shall be checked to ensure that all employees have been safely positioned or removed. Each lockout/tagout device shall be removed from each energy isolating device by employee who applied the device.

When authorized employee who applied the lockout/tagout device is not available to remove it, that device may be removed under the direction of the employer, provided that specific procedures and training for such removal have been developed and making all reasonable efforts to contact the employee that his/her lockout/tagout has been removed.

Zero energy state procedures forms shall be completed and on file for every lockout/tagout procedure.

THE USER OR OWNER OF THIS MACHINE HAS THE SOLE RESPONSIBILITY OF APPLYING EFFECTIVE LOCKOUT/TAGOUT PROCEDURES. ATTACHED DISCLAIMER DOES APPLY TO BETENBENDER MANUFACTURING.

BETENBENDER SHEAR LABEL PLACEMENT

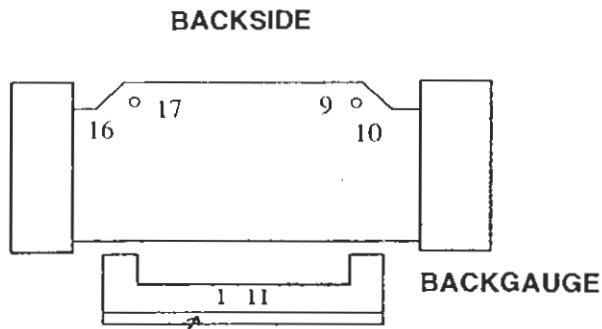
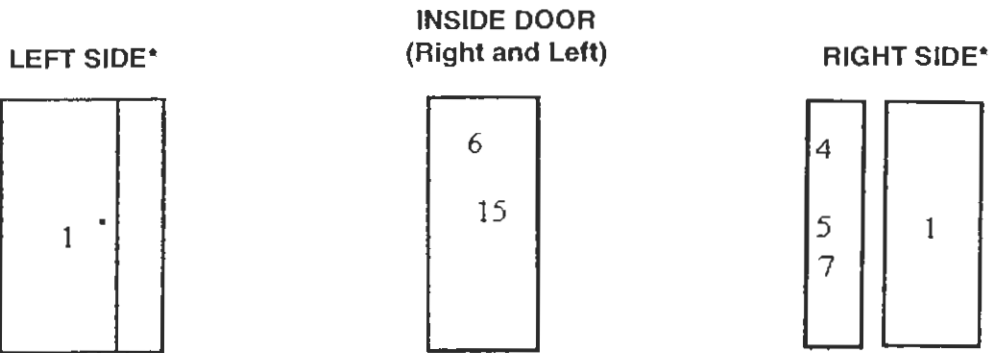
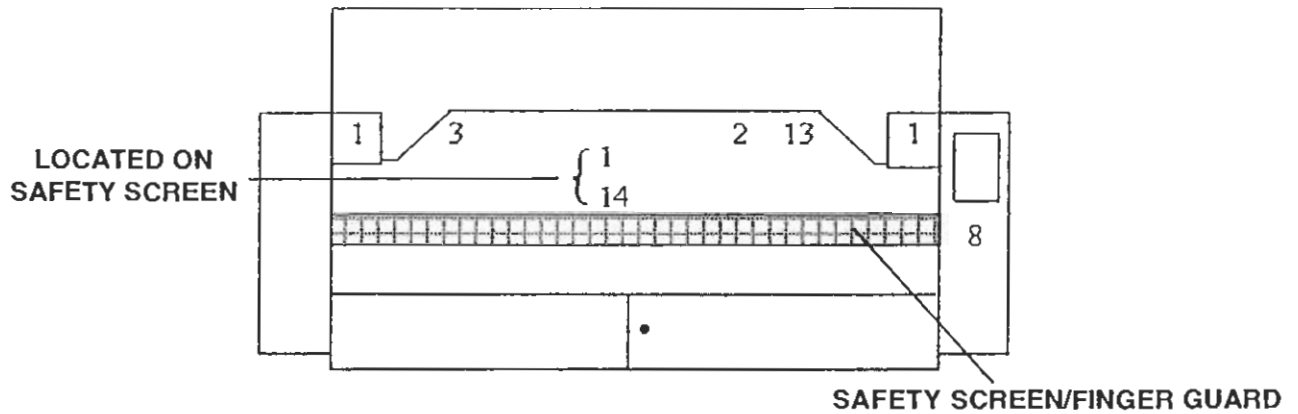

* Yellow and Black Stripe

***All Safety Covers and Guards must remain on the Shear at all times.**



CAUTION

1. INSTALL GUARDS AFTER SERVICING MACHINE.
2. GUARDS MUST BE IN POSITION AND EFFECTIVE PRIOR TO RUNNING MACHINE.
3. DO NOT REMOVE THIS INSTRUCTION PLATE.



2



DANGER

TO REDUCE THE POSSIBILITY OF INJURY . . .

DO NOT PLACE YOUR HANDS BETWEEN THE KNIVES OR BENEATH HOLDDOWNS.



DO NOT PLACE YOUR HANDS BETWEEN MATERIAL BEING SHEARED AND SHEAR TABLE



ALWAYS READ AND UNDERSTAND THE OPERATION, MAINTENANCE AND SAFETY MANUAL BEFORE OPERATING OR SERVICING THIS SHEAR



DO NOT REMOVE THIS SIGN FROM THIS SHEAR

***ALL SAFETY COVERS AND GUARDS MUST REMAIN ON THE SHEAR AT ALL TIMES.**

SAFETY GUIDELINES

SHEAR

- READ AND UNDERSTAND THE OPERATION AND SAFETY MANUAL
- KNOW HOW TO USE THE OPERATOR CONTROLS AND MODES OF OPERATION
- OPERATE ONLY WITH SAFEGUARDING PROPERLY INSTALLED.
- KNOW THE SET-UP AND PROPER METHOD OF OPERATION
- TEST ALL THE REQUIRED OPERATOR CONTROL STATIONS AND MODES OF OPERATION BEFORE EACH SHIFT, EACH JOB RUN AND AFTER EACH BREAK.
- MAKE CERTAIN THE PIECE PART WILL BE CLAMPED BY ENOUGH HOLDDOWNS TO AVOID PLATE "TIP-UP"
- MAKE CERTAIN HOLDDOWN PRESSURE IS SET ACCORDING TO MANUAL - AVOID PLATE "TIP-UP"
- DO NOT SHEAR MATERIAL THAT WILL TIP UP WHEN BEING CUT.
- DO NOT PLACE YOUR HANDS BETWEEN THE KNIVES OR BENEATH HOLDDOWNS
- DO NOT PLACE YOUR HANDS BETWEEN MATERIAL BEING SHEARED AND SHEAR TABLE
- USE HAND TOOLS FOR SMALL OR NARROW PIECE PARTS
- MAKE CERTAIN EVERYONE IS CLEAR OF FRONT AND REAR OF SHEAR BEFORE OPERATING
- TURN OFF OR LOCKOUT OPERATOR CONTROLS WHEN NOT OPERATING SHEAR
- WHEN YOU LEAVE THE SHEAR
 - TURN OFF OR LOCKOUT OPERATOR CONTROLS
 - TURN POWER "OFF"

DO NOT REMOVE THIS SIGN FROM THIS SHEAR

Machine Lockout

1. KNOW THE EQUIPMENT.
2. NOTIFY OTHERS.
3. SHUT OFF POWER.
4. DISCONNECT AND LOCKOUT ALL ENERGY SOURCES.
5. CONTROL OR DISSIPATE SECONDARY ENERGIES.
6. VERIFY THE LOCKOUT.
7. KEEP THE LOCKOUT IN FORCE.
8. FINISH SAFELY.

Always verify the lockout with a voltage tester if direct contact with potentially live electrical components is possible.



3

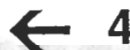

4

***ALL SAFETY COVERS AND GUARDS MUST REMAIN ON THE SHEAR AT ALL TIMES.**

CAUTION:

MACHINE MUST BE LEVELED AND LAGGED TO FLOOR BEFORE USING

← 5



⚠ WARNING

DO NOT GO NEAR LEAKS

- High pressure oil easily punctures skin causing serious injury, gangrene or death.
- If injured, seek emergency medical help. Immediate surgery is required to remove oil.
- Do not use finger or skin to check for leaks.
- Lower load or relieve hydraulic pressure before loosening fittings.

↑
6

7
↓

8 →

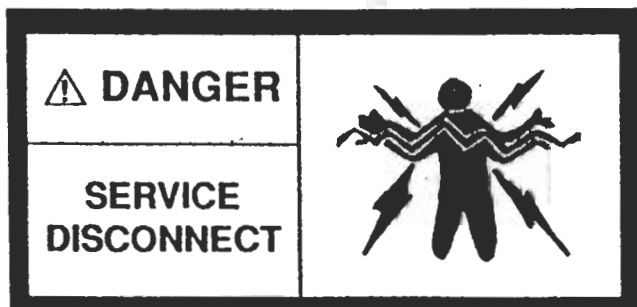

BETENBENDER MFG. Shears and Press Brakes FRACTIONS/DECIMALS/MILLIMETERS		
1/8	.125	3.1750
1/4	.250	6.3500
3/8	.375	9.5250
1/2	.500	12.7000
5/8	.625	15.8750
3/4	.750	19.0500
7/8	.875	22.2250
1	1.000	25.4000

*ALL SAFETY COVERS AND GUARDS MUST REMAIN ON THE SHEAR AT ALL TIMES.

DANGER

TURN OFF MAIN DRIVE OR LOCK-OUT THE OPERATOR CONTROLS BEFORE ENTERING REAR AREA OF SHEAR

← 9



LUBRICATION CHART

COMPONENT	LUBRICANT	INTERVAL
Hydraulic Reservoir	*Type ISO 22 #10 Wt.	Change 2000 hrs/1 yr
Oil Filter	— —	Change 1000 hrs/1 yr
Gibs & Backgauge	*Lubriplate 930AA	40 hours

← 10

* For Reference - Any Equivalent is Acceptable

***ALL SAFETY COVERS AND GUARDS MUST REMAIN ON THE SHEAR AT ALL TIMES.**

WARNING

BEFORE ENTERING BACK OF MACHINE
TO SERVICE OR REPAIR:

1. STOP MACHINE
2. DISCONNECT ELECTRICAL SERVICES

← 11

1/4"

10g^A



12

13 →

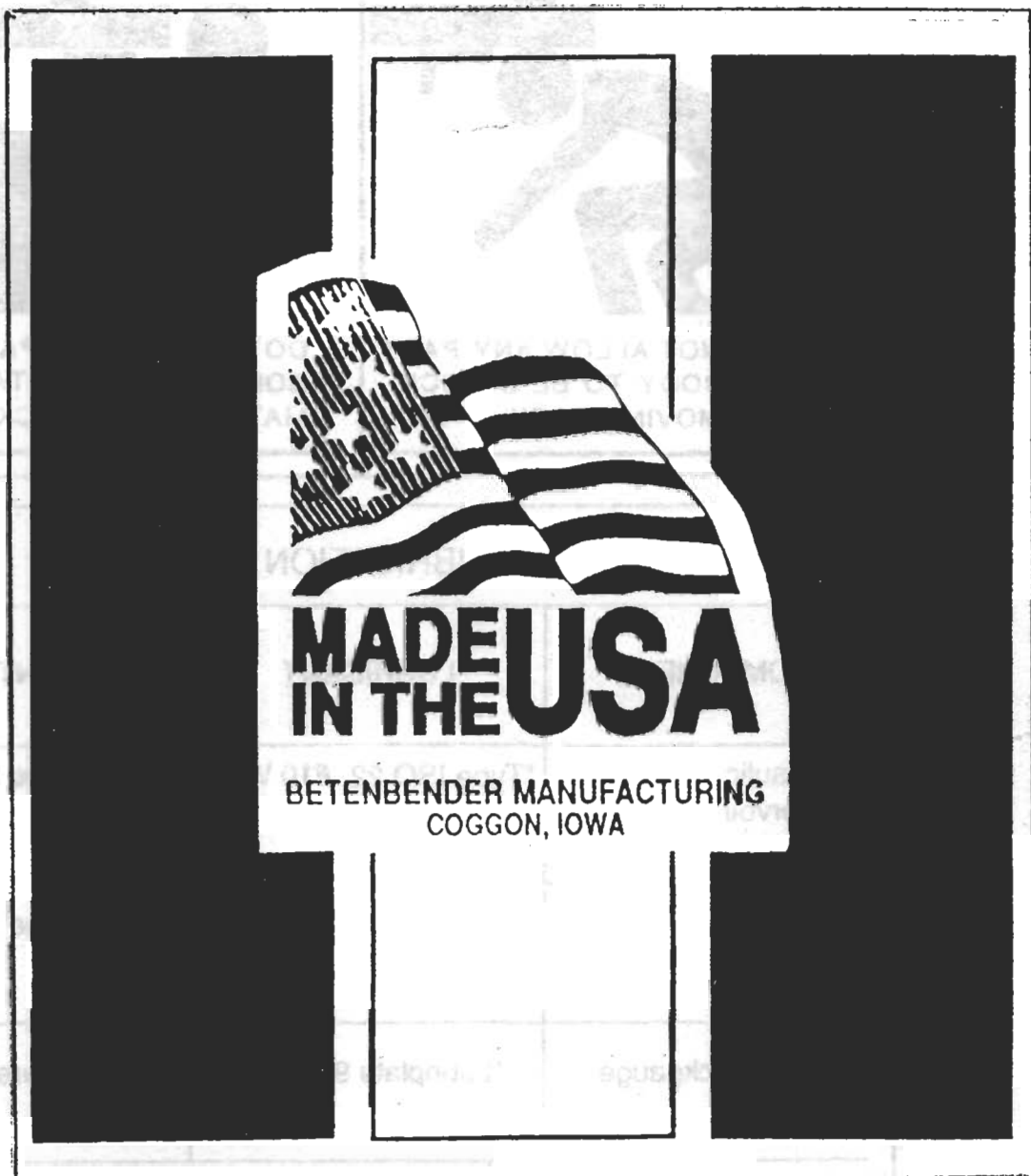

*ALL SAFETY COVERS AND GUARDS MUST REMAIN ON THE SHEAR AT ALL TIMES.

14 →

GUARD TO BE ADJUSTED TO WITHIN 1/4" OF MATERIAL BEING CUT

15 →

RECOMMENDED BLADE GAP CLEARANCES		
Metal Thickness (In.)	Mild Steel	Clearance (In.) Brass, Aluminum, Stainless, Copper, Silicon Steel
0.005-1/32	0.002	0.002
1/16-3/16	0.005	0.002
1/4-1/2	0.017	0.008

16



WARRANTY

BETENBENDER MANUFACTURING, INC. guarantees their product against failure caused by defective workmanship or material which occurs after the product is properly installed within product specifications and during normal use and operation for the period of one year.

We will replace all parts, but not installation or other charges, that our inspection shows to be defective. Written permission for such return must be obtained before shipment. Ship all returns freight prepaid and include a complete explanation of the problem.

The only warranty extended to the buyer by BETENBENDER MANUFACTURING is the above expressed warranty and there are no other warranties, expressed or implied, of merchantability, fitness for a particular purpose, or otherwise which extend beyond the face hereof. BETENBENDER MFG. shall in no event be liable for labor or freight charges or for consequential or incidental damages including, but not limited to, injury to the person or property of buyer or any others, machine down time, and losses or expenses incurred by buyer, arising from the use of this equipment or from this agreement. This warranty constitutes the entire warranty of the manufacturer, BETENBENDER MFG., and no oral representations, warranties or guarantees by any agent of manufacturer or seller shall be binding on BETENBENDER MFG. and no part of this warranty may be modified or extended except by written agreement executed by BETENBENDER MANUFACTURING, INC.

It is our policy to improve its products whenever possible and practical to do so. We reserve the right to make changes, improvements and modifications at any time without incurring the obligation to make such changes, improvements and modifications on any equipment sold previously.

17

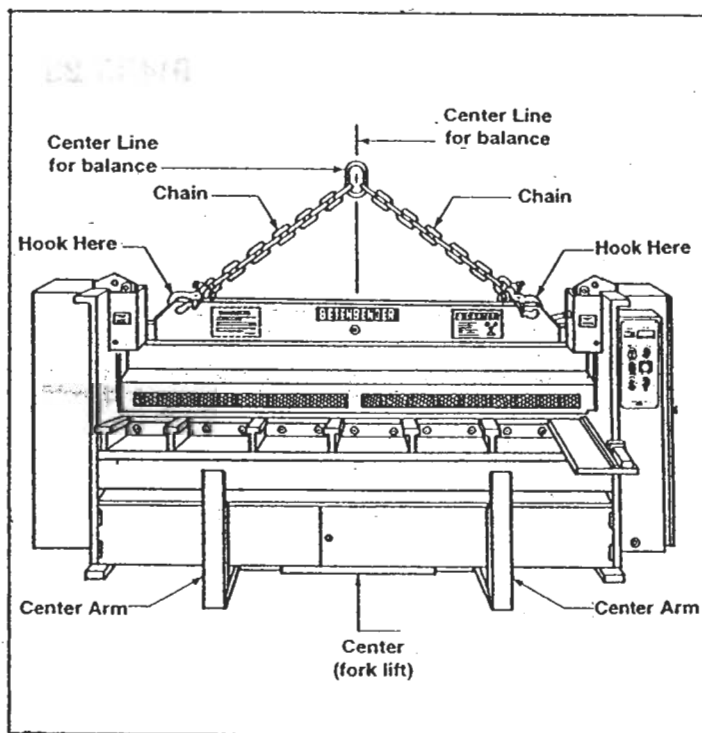

***ALL SAFETY COVERS AND GUARDS MUST REMAIN ON THE SHEAR AT ALL TIMES.**

BEFORE INSTALLING THE SHEAR, READ AND UNDERSTAND THIS MANUAL, TAKING NOTE OF ALL WARNINGS AND CAUTIONS.

SECTION 1: INSTALLATION

Receiving

Check the equipment immediately upon receipt for any loss of parts or damage incurred during shipment. All equipment is sold F.O.B. Betenbender Manufacturing Inc., Coggon, IA. International sale terms are Ex-Works, Coggon, IA. The manufacturer's responsibility for transit damage ends with the carrier's signature on the bill of lading attesting to the arrival in good condition. If you later discover any damage or loss that occurred in shipping, report it promptly to the transport company in order to expedite the necessary claims.

Missing items not noted on the bill of lading, or discrepancies between items ordered and those received, should be reported promptly to:

***ALL SAFETY COVERS AND GUARDS MUST REMAIN ON THE SHEAR AT ALL TIMES.**

RIGGING AND HANDLING

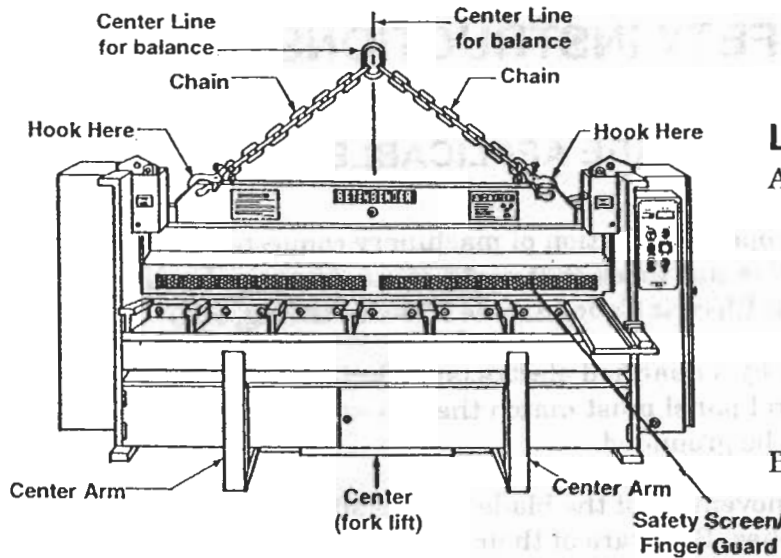

Low Profile Shears

- A. Low profile shears are shipped skid mounted. Lifting with a crane and sling is accomplished by placing clevises into the holes at each end of ram. **DO NOT** remove skids until shear has been rigged into position. If crane service is unavailable, lower it using jacks under the bed at each end.
- B. 10 ga. low profile shear can be handled with a forklift under base of machine. **(CAUTION: Use forklift of sufficient size to handle the machine.)**

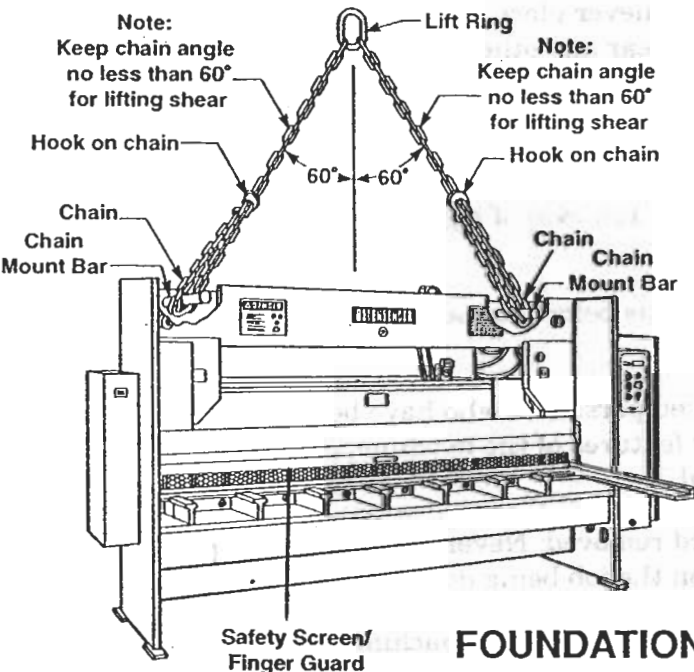

High Profile Shears

- A. A crane and sling must be used when moving a high profile shear. This is accomplished by using the lift bars located on the top of the shear.

FOUNDATION AND PLACEMENT

If your shear is shipped skid mounted, **remove** skids when the machine is in its operating area.

This shear should be placed to meet the following conditions:

- (1) Fork lift should be accessible to both the front and the back of the machine.
- (2) The machine should be placed on 6" reinforced concrete, taking care that the machine is not placed over expansion joints or cracks in the concrete.

To ensure accurate leveling, the level screws must be placed on 8" square, 1/4" thick steel plates. **(Do not put on rubber cushions.)** In each foot of the machine, holes have been provided to anchor the machine to the floor. This is intended to merely prevent the shear from moving after it has been properly leveled.

Anchor bolts of 3/4" diameter may be used. The customer is responsible for the construction of the concrete pads and bolt installation.

NOTE: Leveling bolts are not included.

***ALL SAFETY COVERS AND GUARDS MUST REMAIN ON THE SHEAR AT ALL TIMES.**

WARNING - SAFETY INSTRUCTIONS

THE FOLLOWING SAFETY RULES ARE APPLICABLE:

(1) **Electrical Danger-Misuse** or improper installation of machinery connected to a source of electricity may result in accidental shock that could cause injury or death. Installation must conform to National Electric Code (Article 250-Grounding, etc.)

Electrical Connections must be made by a qualified electrician. Electrical characteristics shown on motor plate and control panel must match the power source; and all electrically powered equipment must be grounded.

(2) **Mechanical Danger-Mechanical movement** of the blade crosshead also actuates the **holddown and backgauge assemblies**. Be aware of their movement by staying away from the **points of operation; specifically--never** place any part of the body under the crosshead, **within the blade area or near any other moving part**. Never stand or sit on anything while feeding machine that could cause you to slip or fall into the cutting area. Failure to comply may lead to **bodily injury**.

Safety guards must not be removed, especially ones that guard the **metal cutting blade, holddown, controls and motor pump**. Any removal of a **guard may lead to bodily injury**.

(3) Perform all installation and set-up operations **before connecting power for electrical start-up**.

(4) The machine is to be operated by **authorized personnel** who have been trained by their **supervisor with the working and safety features of the machine**, and by **reading and understanding the Operators Manual**.

(5) Never operate the machine with any guard removed. **Never eliminate or by-pass any safety devices**. Safety guards are based on **the job being done**.

(6) Never make **adjustments, repairs, replacements or leave machine with power "ON"**.

(7) Avoid accidental start-up.

(8) Do not use machine if **servicing is required**.

(9) Use safety glasses, safety shoes and **required protective tools**.

(10) **Keep work areas clean and in proper order**.

(11) Be alert to all potential hazards. Never become **careless or over confident**.

(12) **Always inch ram to bottom of stroke, turn keylock selector to "OFF", and open the disconnect switch before changing the fluorescent line bulb**.

Note: All guards must be in position and effective before operating the power shear.

***ALL SAFETY COVERS AND GUARDS MUST REMAIN ON THE SHEAR AT ALL TIMES.**

CONNECTING ELECTRICAL SERVICES

Connect the line side of the disconnect switch to an electrical line of proper voltage, phase, hertz and size. Only one power connection is required. Use at least the **SAME SIZE** service entrance cable to connect the starter to the motor. The motor must rotate in the proper direction. (Clockwise when viewed from fan end, or from arrow that is cast in pump.)

Overload protection for drive and backgauge motors is provided in the control panel. If thermal overloads cut out motor, a short time delay is required before it can be operated again. If overload keep continuing, first check for drop in line voltage.

CAUTION: Electricians checking direction of rotation should be cautioned not to operate the shear until it has been thoroughly checked, cleaned, leveled and lubricated. A wiring diagram is furnished in the electrical control box.

LEVELING

Remove the front finger guard and place a precision level (.001/ft) lengthwise on the machine portion on front of the lower blade. See Illustration 1-A in this way you can level the machine left to right using the leveling screws on the front feet.

Secondly, place the level on each end of the same machined surface at a right angle to the blades and level front to back using the rear leveling screws.

It is important that the machine is properly leveled on all four points so there is no camber or twist to the machine.

This should be checked periodically to ensure accurate blade clearance for the length of the cutting area.

IMPORTANT - Immediately reinstall the finger guard after leveling. If the machine is shipped on a pallet, be sure to *remove from pallet and place directly on flooring.*

ILLUSTRATION 1-A

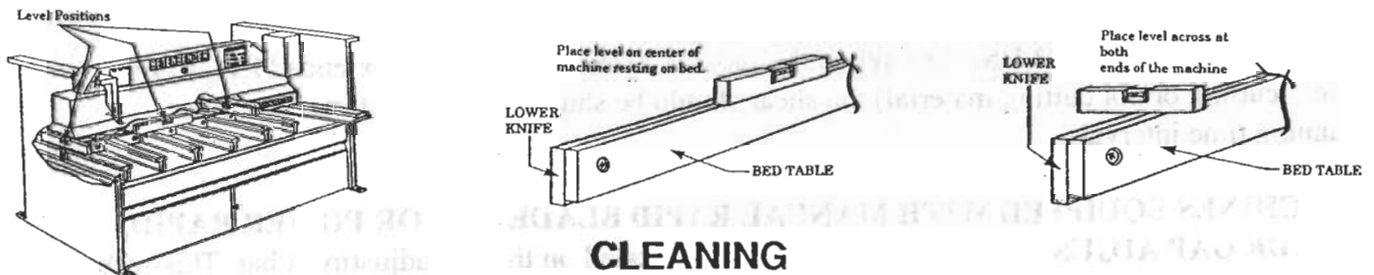

CLEANING

In spite of precautions taken in preparing the shear for shipment, dirt and foreign material may find their way into the ways and other parts during transit, and can cause considerable damage unless thoroughly cleaned. It is extremely important to inspect ways, cylinder rods, gauges, etc., and thoroughly clean any dirt and foreign material that may have accumulated. **DO NOT attempt to blow dirt out with an air hose as this may force some foreign material into undesirable areas.** Remove rust proofing compound with an acceptable solvent. (Always use safety glasses to protect eyes and gloves to protect hands.)

INITIAL STARTING PROCEDURE

- (1) Lubricate gibs.
- (2) Start motor (previously checked for proper rotation).
- (3) Remove shipping blocks from blade.
- (4) Using Rake angle switch, switch to Rake "UP".
- (5) Check Blade Clearance with feeler gauge. (See Blade Clearance.)
- (6) Depress footswitch to stroke shear.

***ALL SAFETY COVERS AND GUARDS MUST REMAIN ON THE SHEAR AT ALL TIMES.**

LUBRICATION

Proper lubrication extends the life of your Betenbender Shear. Following manufacturer's procedures will ensure a long working relationship between your workforce and your Betenbender Shear. We offer three types of lubrications systems:

- (1) Manual Lubrication
- (2) One-Shot Lubrication
- (3) Automatic Lubrication

MANUAL LUBRICATION

Grease the two zerks on the backgauge and also the two zerks on each end of the gibs at 8 hours of running time intervals.

ONE-SHOT LUBRICATION - Optional

NORMAL USAGE: Using the grease pump attached at lube station, manually pump grease into the mainline. This will supply lubricant to the gibs. All zerks should be checked and regreased as necessary.

EXTENDED USAGE: the one-shot grease pump should be operated every 8 hours of running time. All zerks should be checked and regreased as necessary.

AUTOMATIC LUBRICATION -Optional

NORMAL USAGE: each time the shear is initially turned on lubricant from the lube station is applied to the gibs.

EXTENDED USAGE: When the shear is permitted to run for extended lengths of time (cutting or not cutting material) the shear should be shut down and restarted at 8 hour running time intervals.

MACHINES EQUIPPED WITH MANUAL RAPID BLADE GAP OR POWER RAPID BLADE GAP ADJUSTMENT - A grease zerk is located on the gap adjustment bar. This zerk should be greased ANNUALLY.

LUBRICATION NOTE:

All zerk fittings should be checked and regreased as necessary when shutting off the shear during extended running. Otherwise, once per 8 hour running time should be sufficient. Regreasing intervals will be dependent upon climatic conditions under which the equipment is being run.

***ALL SAFETY COVERS AND GUARDS MUST REMAIN ON THE SHEAR AT ALL TIMES.**

**ILLUSTRATION 1-B
ONE-SHOT AND AUTOMATIC LUBRICATION**

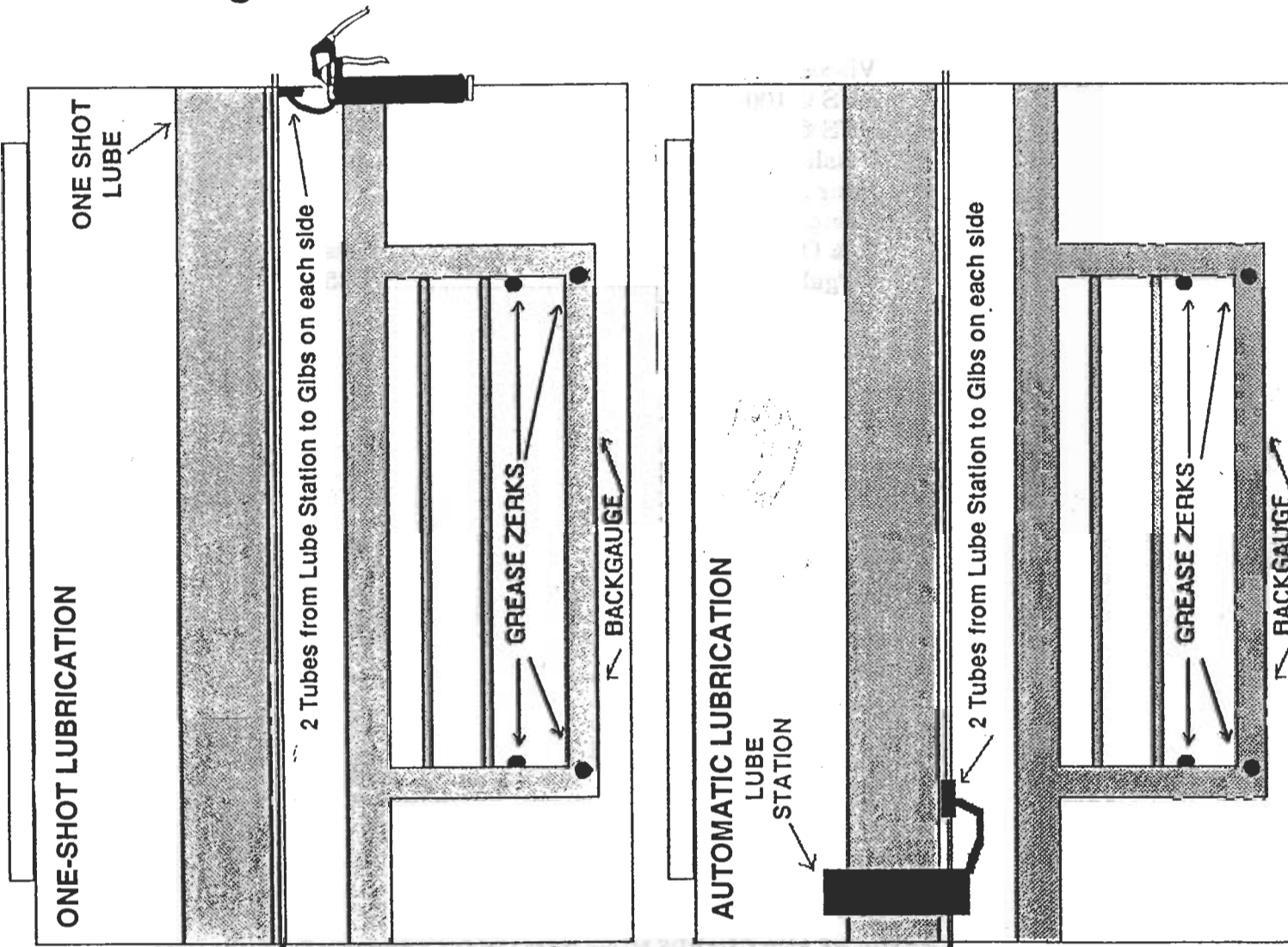

***ALL SAFETY COVERS AND GUARDS MUST REMAIN ON THE SHEAR AT ALL TIMES.**

HYDRAULIC OIL

Betenbender Manufacturing, Inc. recommends that the hydraulic oil be analyzed by your local oil supplier to determine when it should be changed rather than make a change on an arbitrary time schedule. This procedure will often extend its useful life.

Certain oils and hydraulic fluids are not compatible with the hydraulic system of this shear, their use will cause damage. Betenbender Manufacturing recommends the use of **SAE 10.***

It is **ESSENTIAL** that the oil be clean and precautions should be taken to prevent its contamination with any foreign material. **Dirt should be wiped away** from the filler cap on the oil reservoir. When transferring oil always make sure that the container is **clean** before being used. When adding or refilling use only the recommended oil or its equivalent, use a **fine metal strainer** to filter it carefully when putting it into the reservoir.

The maximum safe operating temperature of hydraulic oil is 150° F. Under normal operating conditions this temperature will **not be** exceeded. Excessive oil temperature is generally an indication of potential trouble such as excessive pressure, clogged filters, worn pump or high ambient temperature.

*API Gravity

Viscosity Index Min.	80
SUS @ 100	210
SUS @ 200	48
Flash	425
Pour	-18
Foam	
R & O	Pass
wt/gal	7.35

***ALL SAFETY COVERS AND GUARDS MUST REMAIN ON THE SHEAR AT ALL TIMES.**

ILLUSTRATION 1-C LUBRICATION CHART

COMPONENT	LUBRICANT		INTERVAL
	Mobile	Texaco	
Hydraulic Reservoir	* DTE OIL 25 SAE - 10	* RANOD OIL HD 46	Refill annually
GIBS	* MOBILE GREASE SPECIAL	* TEXCLAD 2	40 hrs.
BACKGAUGE			Monthly

*FOR REFERENCE – ANY EQUIVALENT IS ACCEPTABLE

SPECIFICATIONS AND TEST RESULTS

Product: Hyd. OIL SAE 5, 10, 20, 30	Oil # 0301-0				Weight:
Characteristics:	SAE 5	SAE 10	SAE 20	SAE 30	
API Gravity	29.4	28.7	28.2	27.3	
Viscosity Index	80	80	80	80	
SUS @ 100	105	210	310	510	
SUS @ 210	39	48	53	63	
Flash	385	425	445	485	
Pour	-20	-18	-15	-10	
Foam	Pass	Pass	Pass	Pass	
R & O wt/gal	Pass 7.32	Pass 7.35	Pass 7.38	Pass 7.42	

No foam Hydraulic Oils are a blend of virgin base stocks which provide excellent natural seal swell characteristics. They possess anti-foaming and anti-rust properties. Excellent service is provided by these oils in light and medium duty hydraulic service.

ILLUSTRATION 1-D

MACHINE SIZE	GALLONS
5' X 10 ga	12
6' X 10 ga	16
8' - 12' X 10 ga	20
4' - 8' X 1/4"	32
10' X 1/4"	29
12' X 1/4"	38
4' X 1/2", 3/8" & 3/4"	55
6' X 1/2", 3/8" & 3/4"	74
8' X 1/2", 3/8" & 3/4"	75
10' X 1/2", 3/8" & 3/4"	76
12' X 1/2", 3/8" & 3/4"	90
2' X 1/2"	13
2' X 3/8"	13
1" X 10"	13

*Tank sizes vary according to how it is attached to the machine

***ALL SAFETY COVERS AND GUARDS MUST REMAIN ON THE SHEAR AT ALL TIMES.**

SHEAR SET-UP

- (1) Leveling the shear:
 - A. Level length of bed and front to rear support.
 - B. Using bolt holes drilled and tapped in pad, 7/8 x 8 bolts located in each corner, you can level the machine. Shim until all four pads are solid on the floor. Leveling screws are not to be used to support machine, just to level.
- (2) Check rotation of motor. Arrow cast in pump, indicates proper rotation. Turn on/off momentarily.
- (3) Check ram:
 - A. Check vertical travel of ram. Top of upper ram relief should be $\pm 2^\circ$ closer to the front, than the bottom of the ram.
 - B. Each end of the machine has adjustment screws to adjust the gap. (Distance between the blades.)
 - C. It may be necessary to loosen both ends to tilt the ram. Tighten gib bolts until all bolts are snug (5-10 pounds torque). Grease gibs before adjusting. Don't tighten excessively, leave room for the grease.
- (4) Setting the gap:
 - A. Adjusting bolts: Loosen front, tighten back to close, reverse to open. Be careful, do not change tilt of the gibs.
Set gap for material to be cut.
.002 1/8"
.015 1/4"
.025 - .030 3/8"
.030 - .050 1/2"
 - B. Center of ram will need to be closer to allow for spring back, on longer machines more bow will be required. For example, light gauge material on a heavier 12' x 1/2" is not recommended without adjusting the bow. This is done by adjusting bolt located on back of ram; in center of blade.
 - C. To cut light gauge material on 1/2" machine, loosen adjustment bolt in back of ram. Adjust gap to recommended setting for material being cut.
 - D. There is not one gap setting for all materials. In shorter machines center gap may not be as critical, but it still needs to be adjusted.
- (5) Installing squaring arm:
 - A. Bolt into place (plate or table extension.)
 - B. Next install gauge bar. Square bar by trim cutting 4'x4' sheet of material. Refer to drawing in Operator's Manual, Illustration 2-C, pg. 26.
 - C. After bar is square install drive pins and plate in table.
- (6) Installing scales on squaring arm (or support arm):
 - A. Measure from knife to scale slot and cut scale to fit (cut 0"-5" off).
 - B. Drill hole and tap in drive rivets to hold scale.
Or Use . . .
 - C. Double sided tape (if squaring arm and scales are clean).

***ALL SAFETY COVERS AND GUARDS MUST REMAIN ON THE SHEAR AT ALL TIMES.**

- (7) Backgauge:
- A. Be sure bar is vertical.
 - B. Nuts at the front of the backgauge screws may need to be adjusted snugly. (Loosen set screws, adjust nut, tighten set screws)
 - C. Adjust bar with nuts on spring load assembly, to parallel or fine adjustment.
 - D. To set readout:
 - 1. Move to 6" on display.
 - 2. Turn off display.
 - 3. Move bar to 6".
 - 4. Turn on display.
 - 5. Fine tune with spring adjustment bolts.
 - E. Always adjust gauge forward, to take out backlash that may have accumulated from wear.
- (8) Check holddown:
- A. It may be necessary to tighten or loosen adjustment nut on each pin so that all pins hit at the same time. Check with feeler gauges.
 - B. Be sure the holddown bar is vertical and not tilted.
 - C. Adjust ram counterbalance, this is located on the bottom of the main cylinder on Low Profile machines and on the bottom of the rake cylinder on High Profile machines. Loosen until ram moves first with cycle of the ram going down. Now tighten in until holddown moves first. (Be careful not to tighten too much, as this takes away pressure from main cylinders. Approximately 300 to 400 PSI on gauge for holddown movement only.) Sometimes it is advantageous to increase the holddown pressure to hold light or thin tough material.
- (9)
- A. Lower ram to material and try to cut. Watch the pressure gauge. If the material does not want to cut, the gauge should go to 2500 PSI.
 - B. Quality of the cut has many variables.
 - 1. Material to be cut. Tensile and yield.
 - 2. Gap of blades and gap in center.
 - 3. Rake angle (steeper less power to cut is needed, flatter more power is needed).
 - C. Check for leaks and loose bolts that may have been loosened in shipping.
 - D. Check often in first days of break-in. (Gibs, blade, gap)

***ALL SAFETY COVERS AND GUARDS MUST REMAIN ON THE SHEAR AT ALL TIMES.**

SETTING MICRO SWITCHES

Switch #1 (Upstroke)

- (1) Start machine and lower the rake angle so there is 1/2" to 1-1/2" clearance at C (top of crosshead and top of endplate). DO NOT adjust switch #2 to accomplish this.
- (2) Using the footswitch, cycle machine two or three times. If switch #1 does not shut off, adjust lever on switch to stop cylinder before hitting end of stroke. When switch stops travel of cylinder, there should be 1/2" to 3/4" space (A) between crosshead and endplate. If there is more or less, adjust lever on switch #2. Now cycle machine; it may be necessary to reset switch #1.

Switch #2 (Rake Angle)

- (1) Using rake angle switch, switch to "UP" until crosshead stops. Check to see if stopped by the switch or by hitting the end of stroke of the cylinder. If stopped by the switch, there should be 1/2" to 3/4" space (C) between crosshead and endplate. If there is more or less, adjust lever on switch #2. Now cycle machine; it may be necessary to reset switch #1.

Switch #3 (Downstroke)

- (1) By cycling machine, the blades at D should cross by 1/8" to 1/4" and trip switch #3 to stop down travel. Adjust lever on switch #3 until this is done.

ILLUSTRATION 1-E

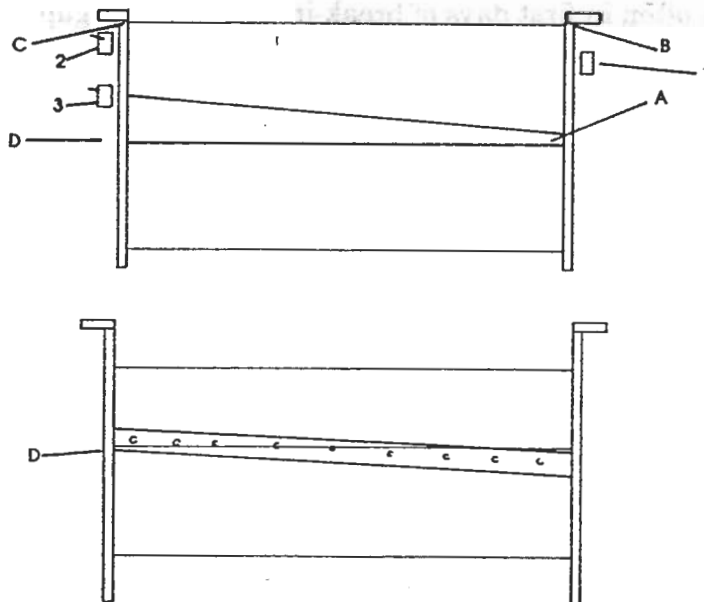

***ALL SAFETY COVERS AND GUARDS MUST REMAIN ON THE SHEAR AT ALL TIMES.**

SELECTION OF OPERATING MODES

SINGLE STROKE

Depressing the footswitch will cycle the holddown and ram to the bottom of stroke. Should the footswitch be released on the down stroke, holddowns and ram will return to top.

NOTE: Stroke length can be shortened when cutting short pieces on right hand end.

INCH STROKE

Change run switch to jog position depressing the footswitch to cycle the holddown and ram down to the desired position. Turn jog switch to run. Holddown and ram will return to top.

CONTINUOUS STROKE - Optional

The shear will continue to cycle automatically until footswitch is released. This position is used for high production shearing. Should the footswitch be released on the down stroke, holddowns and ram will return to the top.

STROKE LENGTH CONTROL SETTING - Optional

A stroke length control is provided to shorten the shear stroke when cutting short pieces on the right hand end of the shear. More cuts per minute can be made when short stroking. It is important to adjust the control so the bottom of the upper blade moves down just past the material to be cut. This prevents the top of the upper blade from catching the material on the return stroke.

RAKE ANGLE

Rake angle is the slope of the knife from left to right. If rake is held to a minimum, *camber, twist and bowing* of the sheared material or off cut will also be minimum. As the rake angle decreases, the cylinder load increases.

Rake angle adjustment makes it possible to increase the rake for cutting heavier stock and extends maximum capacity of the machine.

NOTE: This does not mean the shear is capable of shearing short lengths of a thicker material. Care should be taken to avoid trying to shear any material with 30 Rockwell C hardness or better. You can damage the blades by overloading them in a localized area

ILLUSTRATION 2-A

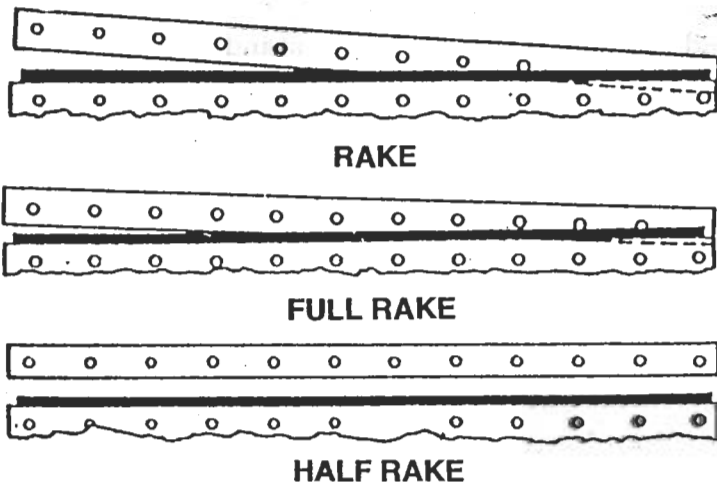

Exaggerated for clarity, this drawing illustrates rake.

ILLUSTRATION 2-B

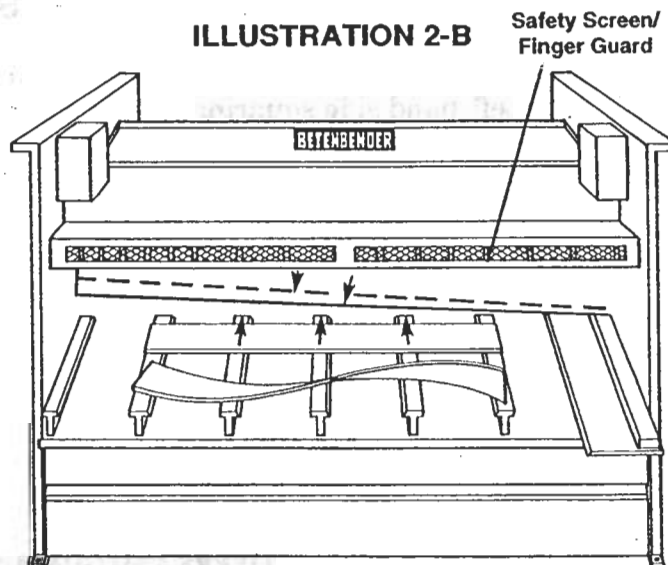

***ALL SAFETY COVERS AND GUARDS MUST REMAIN ON THE SHEAR AT ALL TIMES.**

HYDRAULIC SELF-COMPENSATING HOLDDOWN BAR ASSY.

The hydraulic self-compensating bar assembly consists of a holddown plunger and spring unit mounted to a bar and two hydraulic cylinders. On Low Profile machines, the assembly has spring plungers every 4 inches for the first 24 inches and spring plungers 8 inches on center for the remainder of the bar. On High Profile machines, the assembly has spring plungers every 5 inches for the first 24 inches and spring plungers 8-1/2 inches on center for remainder of the bar.

GAUGING

Probably 90% of the inaccuracy problems encountered in shearing result from bad gauging habits. If care is used in seating the stock against the gauge, if gauge settings are frequently checked, and if the correct gauging procedure is used, most of these problems will solve themselves.

LIGHT BEAM GAUGE - Optional

It may be desirable to cut sheets to a scribed line rather than to a gauge. The light beam gauge will aid in shearing to a line by illuminating the scribed line and blade face. Position of the shadow of the light beam gauge is easily adjusted by sliding lamp brackets to desired position. Be sure to "STOP" motor and place the MAIN DISCONNECT SWITCH in the "OFF" position and lock before attempting to adjust or replace lamps.

BACKGAUGE

When gauging for a cut or resetting the backgauge, always run the gauge out beyond the desired setting and then move the gauge in, to the required reading on the counter.

NOTE: Only "SLOW" should be used for jogging to the final setting.

Should the gauge bar become convex the piece may rock and be out of parallel.

EXTENDED SQUARING ARM - Optional

A 4' squaring arm on the right-hand side with an inlaid scale is standard. Left-hand side squaring arm or an extended squaring arm is optional for squaring large sheets.

***ALL SAFETY COVERS AND GUARDS MUST REMAIN ON THE SHEAR AT ALL TIMES.**

END HOUSING

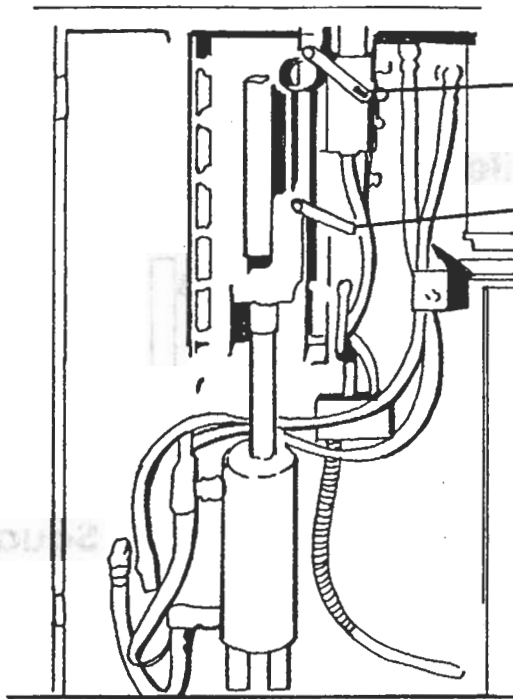

A. View of 10 ga. and 1/4" Machine

A. Up limit switch for power rake.*

B. Lower limit switch stroke control. Blade travel should be less than 1/4" crossover at end of shear blade.

* Approximately 3/8" to 1/2" opening between blade and top of end housing.

OPERATING LEVERS (ON LIMIT SWITCH)

Anti-slip operating level clamp

All of the operating levers utilize the same superior locking technique in fastening the lever to the operating shaft. As show in the illustration, when the prevailing torque nut is tightened, the clamping pin "wedges" against the knurled operating shaft. When properly tightened, an anti-slip connection is the result.

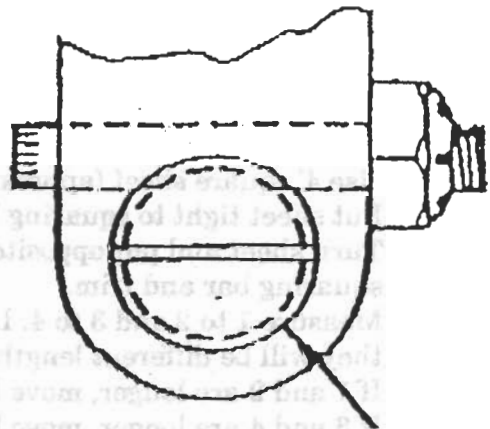

Operating Shaft

CAUTION: DO NOT OVER-TIGHTEN!

***ALL SAFETY COVERS AND GUARDS MUST REMAIN ON THE SHEAR AT ALL TIMES.**

CHECKING SQUARENESS OF SQUARING BAR

ILLUSTRATION 2-C

Shear Knife

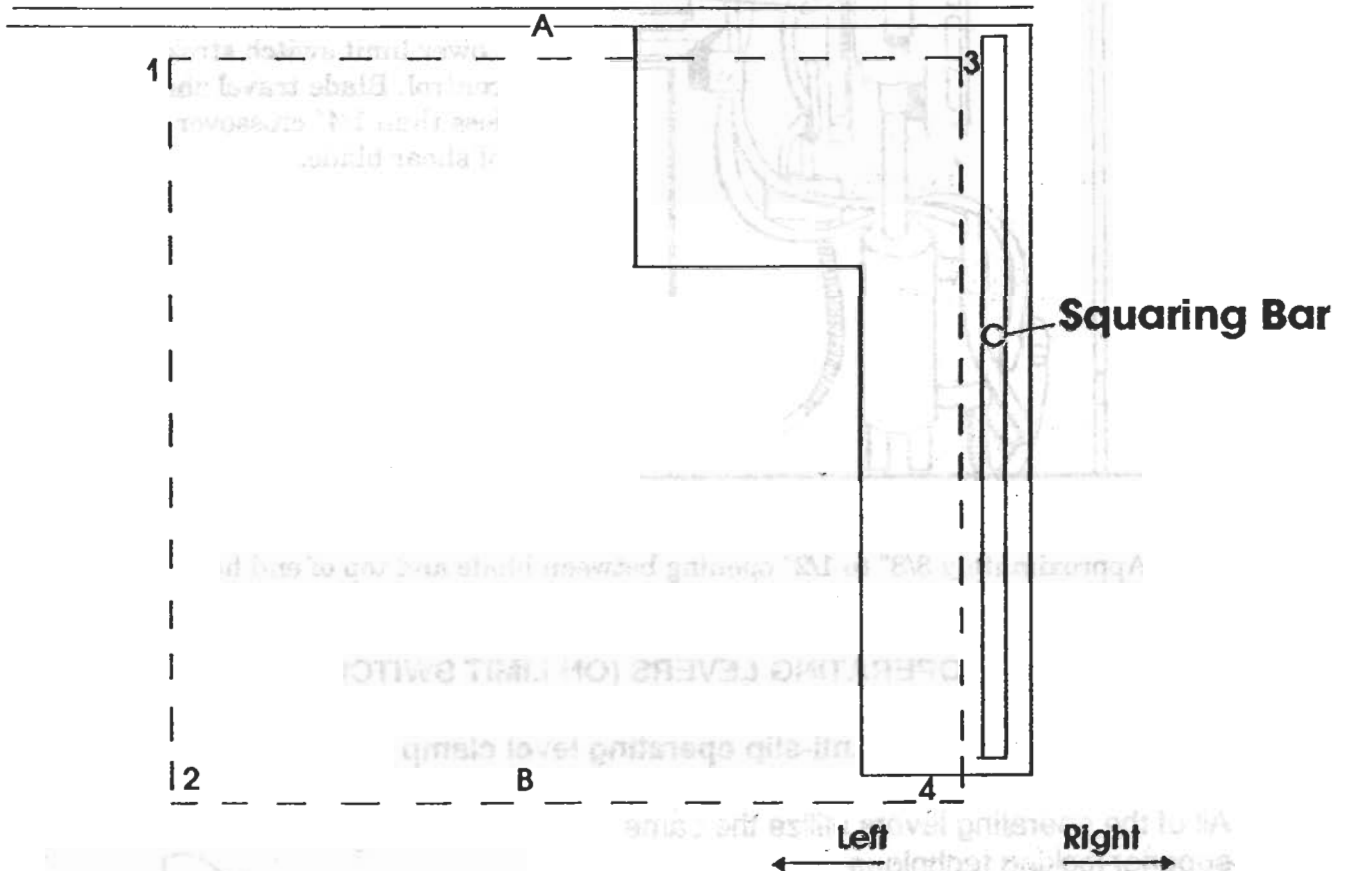

- (1) Use 4' square sheet (approx.)
- (2) Put sheet tight to squaring bar (C) and trim on end (A).
- (3) Turn sheet and put opposite end (B) in shear with side of sheet (C) towards squaring bar and trim.
- (4) Measure 1 to 2 and 3 to 4. If square; should be same length. If not square, they will be different lengths.
- (5) If 1 and 2 are longer, move bar to left.
If 3 and 4 are longer, move bar to right.
- (6) When square, drill and pin bar.

***ALL SAFETY COVERS AND GUARDS MUST REMAIN ON THE SHEAR AT ALL TIMES.**

SETTING BLADES

DETERMINING BLADE CLEARANCE

Universal blade clearance is preferred by many shear users as it permits shearing of a wide range of thickness without having to change the blade clearance. For example: Shears are shipped from the factory with a blade clearance of .010". With this setting, acceptable cuts may be obtained on 1/4" mild steel all the way down to 20 gauge. **(NOTE: This is an arbitrary setting for shipment as clearance may close during transit and installation. Once installed a closer universal blade clearance can be set; never any closer than 0.0015" at the center and 0.0025" at the ends, so the blades do not rub.)**

A good rule of thumb for universal blade clearance is to set the clearance as wide open as practical for the thinnest material to be sheared without an objectionable burr and then use this setting up through capacity thickness.

Under certain conditions a more optimum blade clearance may be desired. Wide off-cuts of 1/4" steel that is harder than normal or somewhat thicker (on high side of mill tolerance) may not cut through with a close blade setting. In such a case merely increase the blade clearance not to exceed **15% of the material** thickness. Conversely very thin materials may require a **reduction in blade clearance** to minimize burring. When a shear is used **exclusively on a given thickness of steel**, an optimum clearance of **10% of material thickness**, will usually produce the best appearing edge.

***ALL SAFETY COVERS AND GUARDS MUST REMAIN ON THE SHEAR AT ALL TIMES.**

BLADE CLEARANCE

Blade clearance must be set to get a square cut on varying thickness of metal.

When shearing mild steel with back pieces greater than 6 to 8 times the material thickness, the blade gap should be set between 4 and 7% of the material thickness. When shearing narrow strips and trim cuts, the blade gap can be closed to approximately 4% of material thickness, or just before a double shear results.

Double shear is characterized by a bright polished appearance on the sheared edge from knife penetration and then another polished condition from the blade re-shearing the edge after fracture occurs.

A word of caution on too large a blade clearance!!! All shear manufacturers will tell you that hydraulic shears cannot be overloaded. This is true--BUT too great a clearance may cause the material to fold and wedge between the blades. This wedging action can damage the shear. Hydraulic design *does not* prevent this type of damage.

CLEARANCE SETTING is done by adjusting gib bolts located on each end of the shear (CAUTION: Adjust one end at a time.)

SETTING THE GAP OR CLEARANCE OF THE BLADES

- (1) Lower rake angle to just about flat.
- (2) Put machine in jog position.
- (3) Jog ram down until blades cross over.
- (4) Refer to Illustration 2-D in Operators Manual.
Example: To change gap, loosen A & G and tighten E & F.
- (5) Tighten gap to approximately .002" of required setting.
- (6) Jog ram down and check gap every 6" across blade until approximately 6" from other end.
- (7) Repeat steps 4 and 5.
- (8) Return to open.
- (9) Check gap every 6" across blade
- (10) Repeat procedures 1-9. Bring to desired setting.

Center should be approximately .001" -.002" tighter than ends. This can be adjusted by center nut and truss bar on back, center of upper blade.

ILLUSTRATION 2-E CAUTION: At no time do the blades touch each other.

STANDARD BLADE GAP

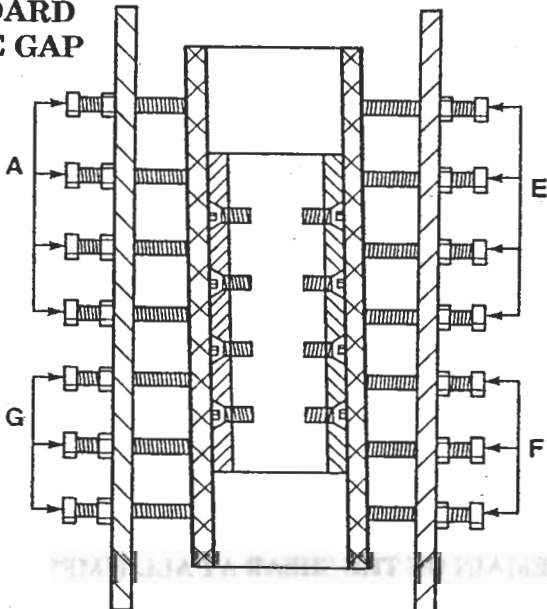

By loosening bolts E & F and tightening bolts A & G, will loosen the gap. To tighten reverse the above procedure.

WARNING: DO NOT tighten bolts too tight and force all the grease out. This will cause bearing to gall, just snug up the bolts. Also be careful when tightening bolts G and F, lower ram, so that one does not squeeze the gibs together. This would result in tearing of the gib.

ILLUSTRATION 2-F

MANUAL RAPID
BLADE GAP
(3/8", 1/2", & 3/4" standard)

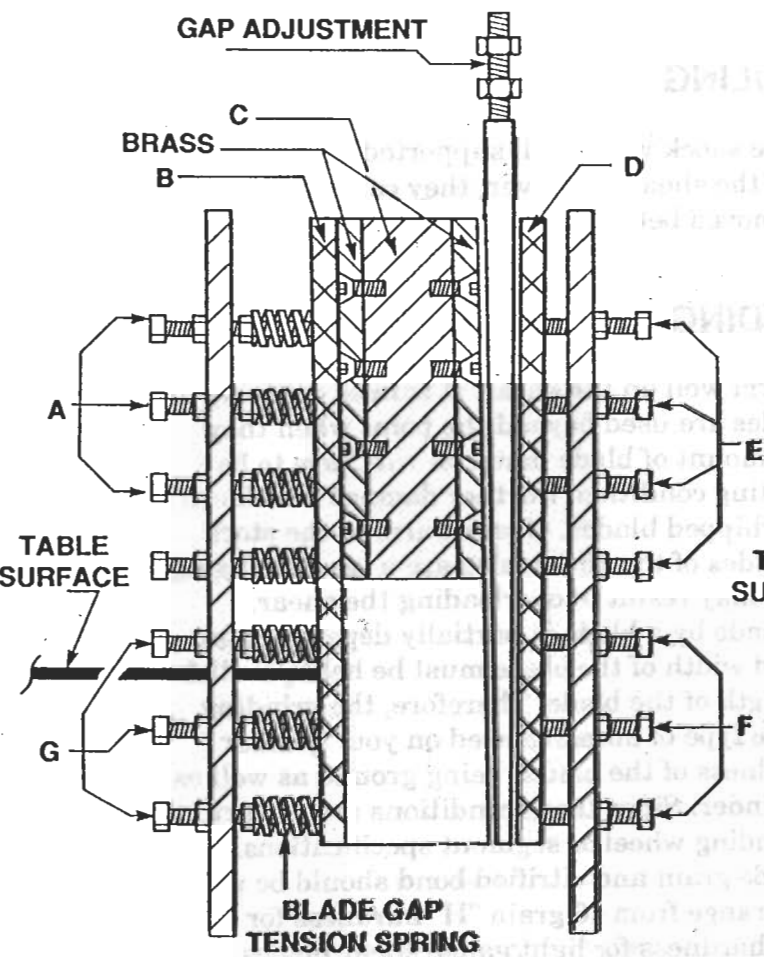
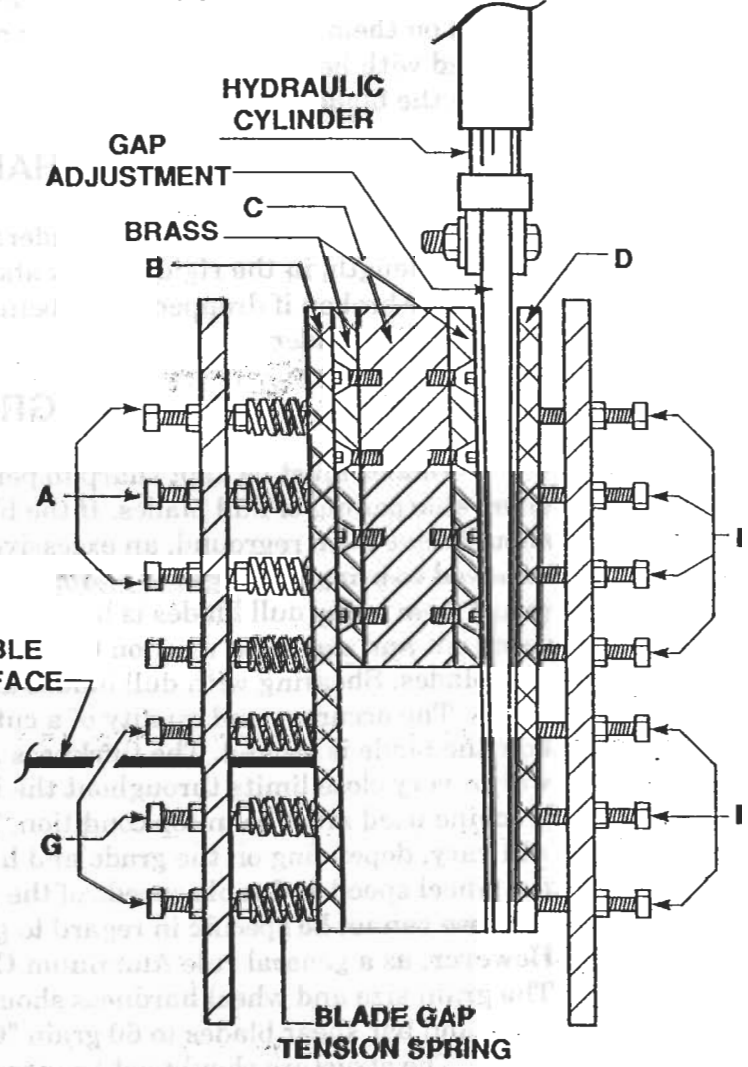

ILLUSTRATION 2-G

POWER RAPID
BLADE GAP
(optional)



- (1) Loosen all springs.
- (2) Lower gap adjustment bar to bottom. (It will be extended all the way).
- (3) Set gap using procedure on the previous page for setting standard gap.
- (4) Retighten springs when completed.

WARNING: DO NOT tighten too tight and force all the grease out. This will cause bearing to gall, just snug up bolts.

Blades are initially set at minimum the clearance.

***ALL SAFETY COVERS AND GUARDS MUST REMAIN ON THE SHEAR AT ALL TIMES.**

MAINTENANCE OF SHEAR BLADES

STORAGE

When not in use, the blades should be stored, preferably in wood boxes, in a dry protected area. **Do not** store the blades where heavy objects can drop or be thrown on them. Following regrinding and prior to storage, the blades should be recoated with heavy rust-inhibiting oil. This will prevent pits resulting from corrosion on the blade surfaces which can become focal points for cracks.

HANDLING

Shear blades can resist considerable shock when well supported throughout their full length, in the rigid knife seats of the shear. However, they can be severely chipped or broken if dropped while being moved between the storage area and the shear or the grinder.

GRINDING

Blades must be kept sharp to perform well on the shear. It is false economy to delay sharpening of dull blades. If the blades are used beyond the point when they should have been reground, an excessive amount of blade material will have to be removed to bring the edges to a proper cutting condition. Further damage which can result from using dull blades is broken or chipped blades. Heavy burrs in the stock being cut and excessive wear on the ram slides of the shear, also are a result of using dull blades. Shearing with dull blades also may result in overloading the shear.

The accuracy and quality of a cut made by a blade is partially dependent on how the blade is ground. The thickness and width of the blade must be held parallel within very close limits throughout the length of the blade. Therefore, the grinding machine used must be in top condition. The type of abrasive used on your grinder will vary, depending on the grade and hardness of the blades being ground as well as the wheel speed and table speeds of the grinder. Since these conditions are so variable, we cannot be specific in regard to grinding wheel or segment specifications. However, as a general rule Aluminum Oxide grain and vitrified bond should be used. The grain size and wheel hardness should range from 46 grain "H" hardness for plate and bar shear blades to 60 grain "G" hardness for light gauge shear blades.

The structure should not be more dense than "8". The wheel should be kept free cutting at all times by frequent dressing. The blade being ground must be flooded with coolant at the point of wheel contact. Do not attempt to remove material quickly. A feed of .001" per pass is sufficient. Under no circumstances should the grinding be so severe as to discolor the blade. The color is an indication of the high temperature to which the blade was subjected. Even if the discolored surface is ground off, the damage remains.

The least that would result, would be a lowering of hardness in the overheated area. The most likely results, however, are grinding checks or areas of severe localized tensile stresses. Either will cause chipping of the cutting edges, and in extreme cases, cracks through the entire section.

***ALL SAFETY COVERS AND GUARDS MUST REMAIN ON THE SHEAR AT ALL TIMES.**

TENSION ON BLADE OR BRACE BAR

It may be necessary to bow the center of the blade closer to the knife in longer and heavier machines (ex. 12' X 1/2" machines, approximately .020 - .030 gap and .002 - .003 center). This will allow for the center to spread. Steel will spring or be stretchy. This allows for an even gap across the machine. As the cut is made, center will push back on the shorter machines. It is not necessary to have as much bow or spring on the blade (ex. 6' X 1/2" machines, approximately .020-.030 gap and .015 - .002 center).

Because the 1/2" machine is set for 1/2" material it is not recommended for light material. For light material it will be necessary to adjust gap and bow of the blade or brace bar.

Sometimes it is possible to cut heavier material with a tight gap, but the quality of the cut may show a **double cut or more crush** of material and it takes more power to cut at tight gap.

SHEARING

Never shear material thicker, or of greater shearing strength than that for which the shear was designed. The indicated capacity of the shear is the maximum thickness to be sheared regardless of width or length being sheared. Do not attempt to shear hardened material.

After turning or changing blades, be certain to remove all tools from the shear table, otherwise they may be pushed between blades accidentally.

If knives have been reground, shims of proper thickness should be used under lower knife to set cutting edge level with table top.

ACCURATE SHEARING

Keeness of the cutting edges, type and thickness of material, proper use of gauges, and size of cut are some of the factors that affect accurate shearing.

Optimum shearing results cannot be expected with stress-filled stock. The release of these strains by cutting causes distortion of the sheared edges. Stress-filled stock **should always be cut** enough oversize to permit a second, narrow (trim) cut. This trim cut will improve the straightness of the sheared edge. Stretcher-leveled or stress relieved stock should be used if utmost shearing accuracy is required. Cold rolled annealed stock can usually be cut with greater accuracy than hot rolled.

For accurate shearing against the backgauge, the operator should feed the sheet against the backgauge, holding it there firmly, but not necessarily with excessive pressure until the cut is in process.

WHERE TO CUT

The hydraulic principle of this shear will allow the operator to make cuts at any point along the bed. However, for accurate shearing without the use of the backgauge, a side gauge should be used. Never exceed the capacity of the shear even in short widths as short widths are as difficult to cut as wider sheets. If the shear stalls because of overload, release the footswitch to return the ram to the top.

More cuts per minute can be made by short stroking and shearing at the right hand side of the table. See "Stroke Length Control Setting".

Small pieces should be gripped by as many holddowns as possible. Never attempt to shear material that is not securely gripped by a holddown or the material may tip and fold between the blades.

SHEARING OF NARROW STRIPS

A certain amount of difficulty may be experienced in the accurate shearing of narrow strips. Narrow strip distortion usually begins to appear when the cut-off width of material is less than 10 to 20 times the material thickness, depending on material properties. The three major difficulties encountered in shearing of narrow strips are camber, twist and bow. The tendency for these conditions is usually greater in the softer and more ductile materials.

CAMBER is the tendency for a strip to distort in such a way that the edges are no longer straight, but may bow to form a long curve. Camber is influenced by the rake of the moving blade, the material being cut, and the width of the strip in proportion to its thickness. Stress-filled stock will camber to a greater degree than stress-relieved stock. The narrower the strip in proportion to its thickness, the greater the camber.

TWIST is the tendency of a narrow strip to twist around itself or to corkscrew. Twist is influenced by the slope of the moving blade, the width of the strip and the thickness and kind of material. The narrower and heavier the strip the greater the amount of twist. Dull blades may increase the amount of twist.

BOW is the tendency of a strip to change or bow from a flat condition. Bow usually accompanies camber and curl. This is almost always due to deficiencies in the material. If there is considerable variation in thickness across the sheet, bowing is almost certain to result and little corrective action can be made at the shear.

***ALL SAFETY COVERS AND GUARDS MUST REMAIN ON THE SHEAR AT ALL TIMES.**

SECTION 3:

MAINTENANCE

With proper maintenance, your Betenbender shear will provide many years of trouble-free service. Other benefits include safer operation, longer blade life and greater accuracy. All of which contribute to producing a better product. Shear cleanliness and general good housekeeping are important. A clean shear is easier and safer to operate and more conducive to better working conditions. When cleaning a shear, use an approved solvent and rags. Never use waste or an air hose.

Inspect your shear periodically. Know how it is supposed to operate so that faulty operation can be detected immediately. Replace any worn parts promptly and check fittings, nuts and bolts for looseness.

PREVENTATIVE MAINTENANCE CHECK LIST

Successful operation of hydraulic equipment largely depends on maintaining clean hydraulic oil. Therefore extra care has been taken to provide proper filtration. To insure continuously clean hydraulic oil, the filters must be inspected not less than every six months and the replaceable cartridge changed as necessary, or at least once each year.

A new shear should be thoroughly inspected at the end of the first month of operation and then every six months thereafter. The first month's inspection should cover the following:

- (1) Check for proper hydraulic oil level and add as necessary.
- (2) Check shear for levelness.
- (3) Check gib surfaces to make sure they are receiving adequate lubrication.
- (4) Check blade clearance for evidence of rubbing. Adjust if necessary.
- (5) Clean backgauge, ways and check wipers. Lubricate.
- (6) Check all electrical connections for tightness.
- (7) Check all hydraulic and lubrication connections for leaks, tighten if necessary.

The six month inspections should cover the following items in addition to above list:

- (1) Clean and lubricate backgauge screws.
- (2) Check backgauge calibration and reset if necessary.
- (3) Inspect blades for sharpness. Clean and oil. Rotate if blades are dull.
- (4) Have a sample of hydraulic oil analyzed by your oil supplier for evaluation whether a change should be made.
- (5) Check condition of filters. Clean and/or change cartridges, as necessary or at least once a year.

When replacing the hydraulic oil, the tank should be thoroughly flushed, the suction line filter cleaned, and the cartridge in the return line filter replaced, before refilling.

***ALL SAFETY COVERS AND GUARDS MUST REMAIN ON THE SHEAR AT ALL TIMES.**

ELECTRICAL COMPONENTS

Electrical components can fail without advance warning. There are many factors that affect the life of electrical components. Because of this, it cannot be stated that after a given time a unit should be replaced. The best protective measure is a *responsible and systematic maintenance program*. Due to the variety of components available, the maintenance program should follow the component manufacturer's recommendations.

Check footswitch daily, before the shear is put into production. Protect the footswitch cable from damage by heavy falling objects. A footswitch when not in use should be moved away from the working area.

NOTE: Driving heavy machinery over footswitch cable could result in cable damage.

HYDRAULIC COMPONENTS

For identification of hydraulic components and circuitry, a hydraulic diagram is furnished with this manual. When changing hydraulic components always make sure the ram is at the bottom of the stroke or blocked to relieve all stored energy. Refer to Hazardous Energy Lockout/Tagout procedures.

MAIN HYDRAULIC CYLINDERS

In order to perform any maintenance on the main cylinders it is necessary to remove them from the shear. Proceed as follows:

- (1) Make certain the ram is at top of its stroke.
- (2) Place **MAIN DISCONNECT SWITCH** in the "OFF" position and use **Hazardous Energy Lockout/Tagout procedures**.
- (3) Block both ends of the ram up, taking any pressure off the frame and ram mounting pins.
- (4) Disconnect the hydraulic lines and cover ends with a protective cover.
- (5) Remove retainers and remove ram cylinder pin, allow piston to lower. Remove retainers and frame cylinder pin. Assemble may now be removed to bench for maintenance.

HYDRAULIC SELF-COMPENSATING HOLDDOWN BAR ASSEMBLY

The individual holddown cylinders should be replaced (as units) if they are damaged or develop leakage. To remove a holddown cylinder, proceed as follows:

- (1) Start machine and run ram to top of stroke, place **MAIN DISCONNECT SWITCH** in "OFF" position and use **Hazardous Energy Lockout/Tagout Procedures**.
- (2) Block both ends of ram.
- (3) Remove front shield.
- (4) To remove cylinder, using a 2 x 4 pry under the holddown bar enough to remove lower pins.
- (5) Disconnect top pin and hydraulic hoses to remove cylinder.
- (6) Reverse procedure for installation. **Replace front shield**. Cycle shear several times to remove air from the cylinder.

Holddown cylinder assemblies are available as replacements.

***ALL SAFETY COVERS AND GUARDS MUST REMAIN ON THE SHEAR AT ALL TIMES.**

CHANGING BLADES

CAUTION: Shear blades can easily cause bodily injury. When handling blades, heavy gloves should be worn; exposed parts of the body such as arms should be adequately protected. Also, blades can be damaged if not handled properly.

- (1) Raise ram to full top position. **Block up** securely.
- (2) Place the MAIN DISCONNECT SWITCH in the "OFF" position and use **Hazardous Energy Lockout/Tagout** Procedures.
- (3) **Remove end barrier guard sections.**
- (4) **Disconnect hydraulic cylinder from holddown beam.**
- (5) **Remove holddown beam. Remove two bolts on each guide.**
- (6) *Moving (Upper) Blade:*
 - A. Place 2" X 4" timbers across the table on **about three foot centers** allowing them to project several inches behind the blade. **On each 2" X 4" timber** place a block with height sufficient enough to **support the blade.** Clamp 2" X 4" timbers in place.
 - B. Remove plow bolts and carefully lower blade **onto block support** using rods through the plow bolt holes.
 - C. Blade may be rotated for remounting or removed from shear.
 - D. Clean blade and blade seat. Remove blade seat burrs with a file.
 - E. Inspect plow bolts for damage. Replace worn or damaged plow bolts.
 - F. Raise blade into position and install plow bolts loosely.
 - G. After **regrinding**, place a full length shim on top (not behind) the blade to maintain **required distance** of the cutting edge to the blade seat.
- (7) *Fixed (Lower) Blade:*
 - A. Remove **side gauges** and squaring arm.
 - B. Remove **plow bolts** while another person supports the blade from behind.
 - C. **Blade may be rotated** for remounting or removed from the shear (from the rear), supported with rods through the plow bolt holes.
 - D. Clean **blade** and blade seat. Remove burrs from blade seat with a file.
 - E. Inspect **plow bolts** for damage. Replace bolts if necessary.
 - F. After **regrinding**, place full length shim under (not behind) the blade to **position the top edge** of the blade flush or a few thousandths below top of the bed.
 - G. **Place blade into position** and install plow bolts loosely.
- (8) **Drive wooden blocks** between blades (as necessary) to flatten and hold shims **in place.**
- (9) **Seat key of each bolt** into groove.
- (10) **Draw bolts up tight.** Start at center and alternately work right and left out to **both ends** of blades. As the nuts **are tightened**, bolt heads should be tapped with a **hammer and rod** to **seat the bolt** heads into countersink.
- (11) Remove wooden blocks.
- (12) Replace squaring arm and side gauges.
- (13) Square side gauges to blade.
- (14) Replace holddown beam. Reconnect hydraulic cylinder.
- (15) Replace all guard sections.
- (16) Reset backgauge and bed scales to cutting edge of fixed blade.
- (17) Establish blade clearance - See "Establishing Blade Clearance," page 36.

***ALL SAFETY COVERS AND GUARDS MUST REMAIN ON THE SHEAR AT ALL TIMES.**

ESTABLISHING BLADE CLEARANCE

Blade clearance must be established using feeler gauges for initial set up or when blades are changed or reground. The following procedure should be used:

- (1) Bring down shear ram until cutting edges of blades cross the right hand edge of shear.
- (2) Stop motor and place DISCONNECT SWITCH in the "OFF" position, and lock.
- (3) From behind the shear, insert the feeler gauge between the blades at the point where the cutting edges cross. The blade seats are machined with a slight relief angle, therefore, an accurate measurement can only be made where the cutting edges of the blades cross.
- (4) If measured clearance needs to be changed: See page 28.
 - A. Remove adjustment covers at each end of the shear.
 - B. Loosen one side of gib bolt; tighten other to bring blade forward or back depending on which side you loosen/tighten until blades have desired clearance.
- (5) Repeat steps 1 through 4 at left hand end of shear.
- (6) Recheck steps 1 through 4 at left hand of shear.
- (7) Lock all gib bolts and replace covers at each end of shear.
- (8) Repeat steps 1 through 3 at center of shear. Center clearance should be .001" less than at the ends. If center adjustment is necessary, tighten the nut on brace bar and this will move center of moving blade toward fixed blade.

ILLUSTRATION 3-A

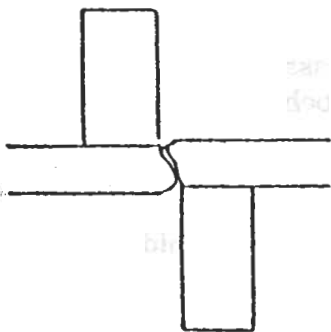

Too much clearance

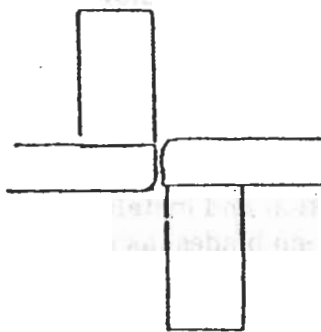

Correct clearance

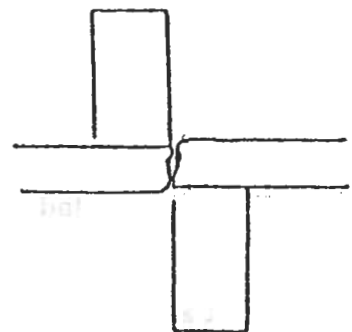

Insufficient clearance

***ALL SAFETY COVERS AND GUARDS MUST REMAIN ON THE SHEAR AT ALL TIMES.**

GRADE OF BLADES

Betenbender Manufacturing, Inc. supplies as standard Mark II H.C.H.C. (high carbon, high chrome) blades. The H.C.H.C. blades are unsurpassed in their ability to retain keen edges and are recommended for shearing high silicone steel and other abrasive material. The exceptional life of each edge makes them ideal for high production shearing.

In addition to the Mark II H.C.H.C. blades supplied, Betenbender Manufacturing can furnish Mark I blades which are chip resistant and can shear a harder grade of stainless and high silicon steels.

REORDERING BLADES

In ordering blades you will enable us to expedite delivery by sending the following information with your order:

- (1) Model number of shear.
- (2) Serial number of shear.
- (3) Specify the blade you require:

Mark II (Shock resistant High Carbon, High Chrome)

or

Mark I (High Carbon, High Chrome for Stainless Steel)

***ALL SAFETY COVERS AND GUARDS MUST REMAIN ON THE SHEAR AT ALL TIMES.**

Mild Steel Shearing Capacities

Mild Steel	10 ga	1/4"	3/8"	1/2"	3/4"
Strip Steel - Dead Soft	10 ga	1/4"	3/8"	1/2"	3/4"
Strip Steel - Half Hard	10 ga	1/4"	3/8"	1/2"	3/4"
Strip Steel - Hard	12 ga	3/16"	1/4"	3/8"	1/2"
Steel Class with Aluminum	10 ga	1/4"	3/8"	1/2"	3/4"
Abrasion Resisting Steel "H" Full Hard	14 ga	3/16"	1/4"	3/8"	1/2"
Abrasion Resisting Steel "S" Med. Hard	14 ga	3/16"	5/16"	7/16"	5/8"
High Carbon - .40 to .50 Car.	14 ga	3/16"	1/4"	3/8"	1/2"
SAE 2340	.082"	.145"	.218"	.291"	.435"
SAE 3140	.080"	.142"	.214"	.285"	.428"
Stainless Steel type #304	.105"	.188"	.281"	.375"	.563"
Brass Gilding Metal 1/2 Hard	.197"	.350"	.525"	.700"	1.050"
Commercial Bronze 1/2 Hard	.197"	.350"	.525"	.700"	1.050"
Red Brass 1/2 Hard	.183"	.325"	.487"	.650"	.975"
Low Brass 1/2 Hard	.180"	.320"	.480"	.640"	.960"
Cartridge Brass 1/2 Hard	.175"	.312"	.468"	.625"	.937"
Yellow Brass 1/2 Hard	.175"	.312"	.468"	.625"	.937"
Copper, Electrolytic Tough Pitch 1/2 Hard	.269"	.480"	.720"	.960"	1.440"
Inconel Annealed H.R.	.108"	.192"	.288"	.384"	.576"
Inconel Natural H.R.	.095"	.168"	.253"	.337"	.506"
Inconel Annealed C.R.	.111"	.198"	.297"	.396"	.594"
Inconel Hard C.R.	.084"	.150"	.225"	.301"	.451"
Monel Soft C.R.	.140"	.250"	.375"	.500"	.750"
Monel 1/4 Hard C.R.	.130"	.232"	.348"	.465"	.697"
Monel 1/2 Hard C.R.	.120"	.215"	.322"	.430"	.645"
Monel 3/4 Hard C.R.	.113"	.202"	.303"	.405"	.607"
Monel Hard C.R.	.106"	.190"	.285"	.380"	.570"
Silicon Steel	.116"	.207"	.311"	.415"	.622"

* Overloading blades in a particular area may cause damage (chips or cracks) to the blades.

** Always be sure that two holdowns clamp the part being sheared.

***ALL SAFETY COVERS AND GUARDS MUST REMAIN ON THE SHEAR AT ALL TIMES.**

SHEAR BLADES

REGRINDING

Improperly ground blades drastically reduce blade life, cutting efficiency and quality. **Betenbender Manufacturing** can help you keep your shear blades in factory new condition with our fast, dependable, regrinding service. Most users find it convenient to have a spare set of blades.

To obtain the best performance and accurate cutting, it is essential that blades not only be suited to the material and thickness being cut, but properly cared for. Dull blades result in poor quality of the cut and continued use of dull blades will reduce their useful life.

Shear blades **must** be reground to the same exacting tolerances as new blades to insure quality cuts and maintain a high level of productivity. The recommended tolerances are as follows:

WIDTH - Parallel to within .005" from end to end.

THICKNESS - Parallel to within .003" from end to end.

No variation greater than .001" within any 12" of length.

GRINDING LIMITS

The blades are designed to allow for regrinding both the thickness and width. However, there are practical limits to the amount of material that can be removed before the blades should be replaced. The following chart can be used as a guide in determining whether your blades are nearing the **minimum** grinding limits:

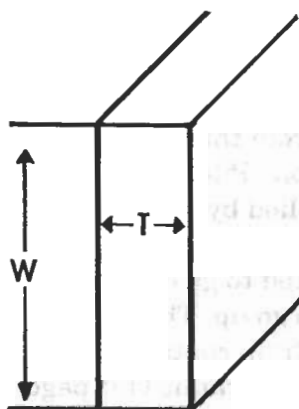

<u>ORIGINAL SIZE</u>	<u>MINIMUM THICKNESS</u>	<u>MINIMUM WIDTH</u>
1" X 3"	3/4"	2-5/8"
1" X 4"	3/4"	3-5/8"
1-1/8" X 5"	7/8"	4-5/8"
1-1/2" X 5-1/2"	1-1/4"	5-1/8"
1-3/4" X 6-1/2"	1-1/2"	6"

Initial blade clearance is adjusted by moving the crosshead in and out. If blade thickness is below the reference minimum (T), proper blade clearance may not be possible. If width is reduced to below the reference minimum (W), the blades may not cross full length.

***ALL SAFETY COVERS AND GUARDS MUST REMAIN ON THE SHEAR AT ALL TIMES.**

TROUBLE SHOOTING

- Noisy Pump
- Shear Does Not Operate

PUMP - Hydraulic Schematic

A balanced vane type fixed displacement pump is directly coupled to the 5-40 HP 1800 RPM motor. The pump may wear due to contaminated oil or excessive pressure from a misadjusted or stuck relief valve. Excessive pressure can also cause broken vanes. The pump is a cartridge type, and the cartridge is easily replaced. A very noisy pump can be caused by a small air leak in the suction line or around any of the pump shaft or housing seals.

- Cannot Cut To Capacity
- Improper Operating Pressure

RELIEF VALVE - Hydraulic Schematic

Limits the maximum operating pressure to 2500 PSI. This setting can be checked with a pressure gauge. Inability to set the proper operating pressure is caused by a defective relief valve. The valve can become worn or stuck from contaminated oil. **If this is the case, see "Hydraulic Oil" on page 18. If one of the relief valve springs becomes fatigued or broken, it can be replaced.**

- Ram Does Not Stroke
- Ram Does Not Return To Top
- Ram Over Travels At Top

DIRECTIONAL VALVE - Hydraulic Schematic

A four way, open center, double solenoid pilot operated directional valve controls the direction of the ram travel. **With both solenoids deenergized, the main spool is spring centered and oil flow from the pump is returned to the reservoir. Pilot pressure to shift this valve is supplied by a built-in 65 PSI check valve. When Solenoid 1B is energized, the valve is shifted to go down. Solenoid 1A is energized to go up. The valve can become worn or stuck from contaminated oil; if this is the case, see "Hydraulic Oil" page 18. If ram will not go up or down, determine if the proper solenoid is energized. The solenoids have manual overrides which can be depressed. If it cannot be shifted either electrically or manually, replace the valve.**

***ALL SAFETY COVERS AND GUARDS MUST REMAIN ON THE SHEAR AT ALL TIMES.**

- Ram Loses Correct Rake Quickly
- Ram Rake Cannot Be Reset

RAKE CORRECTION VALVE

A two way normally closed valve blocks the crossover line except when the "RAKE ADJUST SWITCH" is turned to Up or Down. During rake adjust, this valve is energized to permit oil to be added or subtracted from the crossover line. If this valve leaks, the ram will go out of proper rake quickly. If this valve fails to operate, the rake cannot be reset.

- Low Holddown Pressure
- Ram Drifts Down Excessively

OVER CENTER COUNTERBALANCE VALVE

This valve blocks oil from the lower right hand cylinder in Low Profile machines or the upper left hand cylinder in High Profile machines to prevent the ram from drifting down. After the holddown cylinders clamp, it is opened to allow the ram to come down. The adjusting screw on top of this valve should be set to maintain proper PSI on material being held by the holddown clamps.

- Material Shifts During Cutting

BLADE CLEARANCE

This can be caused by incorrect blade clearance. If the blade clearance is too small, the material will be pushed backwards toward the operator; if it is too large, the material will be drawn into the shear.

KNIVES

Dull knives not only cause shifting of material but will cause a strain on the machine.

- Over Extending Rake

This causes blades not to cross at control end. This can be corrected by raising the rake.

- Not Enough Rake

If there is not enough rake the material will not cut. Extend rake up to correct this problem.

***ALL SAFETY COVERS AND GUARDS MUST REMAIN ON THE SHEAR AT ALL TIMES.**

BACKGAUGE STOP

3" spring needs to be compressed to approximately 2-3/4" for correct tension. Adjusting nut is used to set parallelism. Move adjusting nut for spring tension if large adjustment is required.

CHECK SQUARING OF BACKGAUGE

- (1) Bring backgauge forward to about 7"-8" out from blade.
- (2) Measure from lower blade to Point A.
- (3) Check other side from blade to Point B. (It should be the same.)
- (4) If not the same, adjust Points C & D. (One push, one pull.)

CAUTION: Do not take up all of spring. It may necessary to loosen nut if this is the case. Tight springs give no protection to the screws for shock.

- (5) In order to straighten gauge bar, adjustment may be needed on bolt E. Adjust C then E, adjust backgauge screws first until parallel. Adjust center (E) then ends (C & D). Tighten or loosen gauge bar to straightness. After gauge bar is straight, recheck alignment by repeating steps 1-4.

NOTE: Adjustment of gauge bar.

- (1) Gauge bar needs to be parallel to blade.
- (2) **Limit switches.**
- (3) Setting calibration.

**ILLUSTRATION 3-C
COMPLETE POWER BACKGAUGE ASSEMBLY**

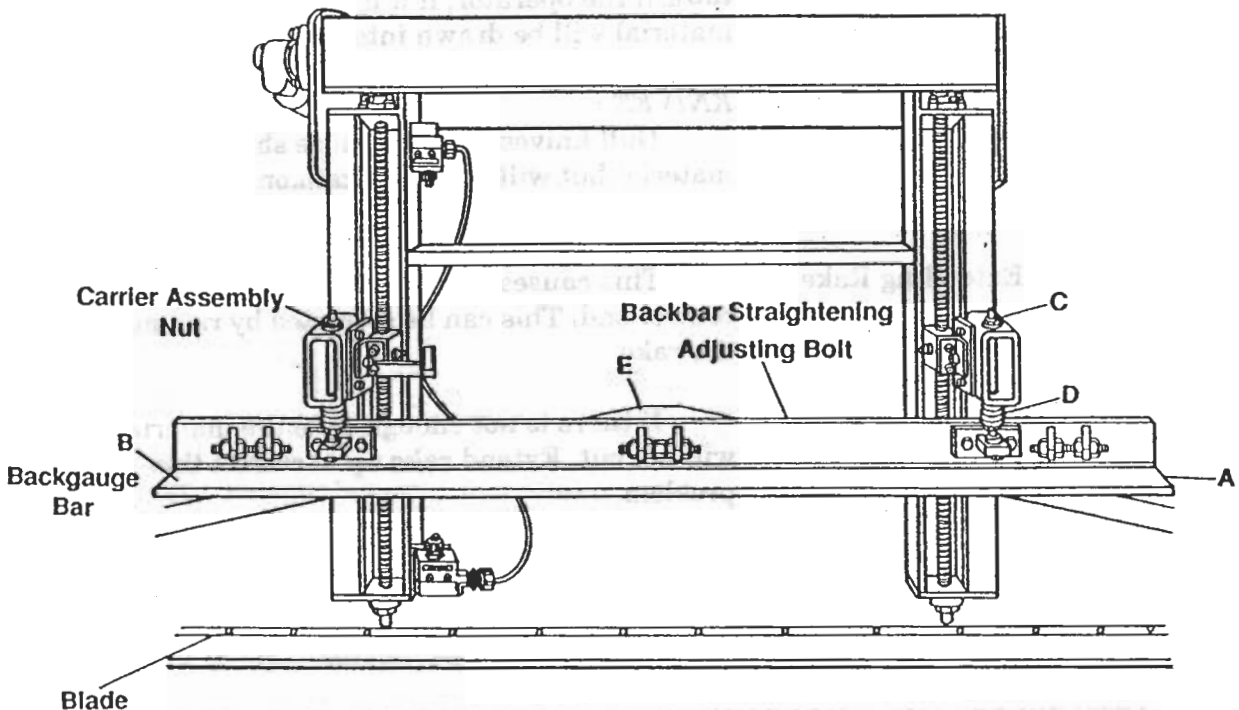

***ALL SAFETY COVERS AND GUARDS MUST REMAIN ON THE SHEAR AT ALL TIMES.**

ILLUSTRATION 3-D

BACKGAUGE (View from the bottom)

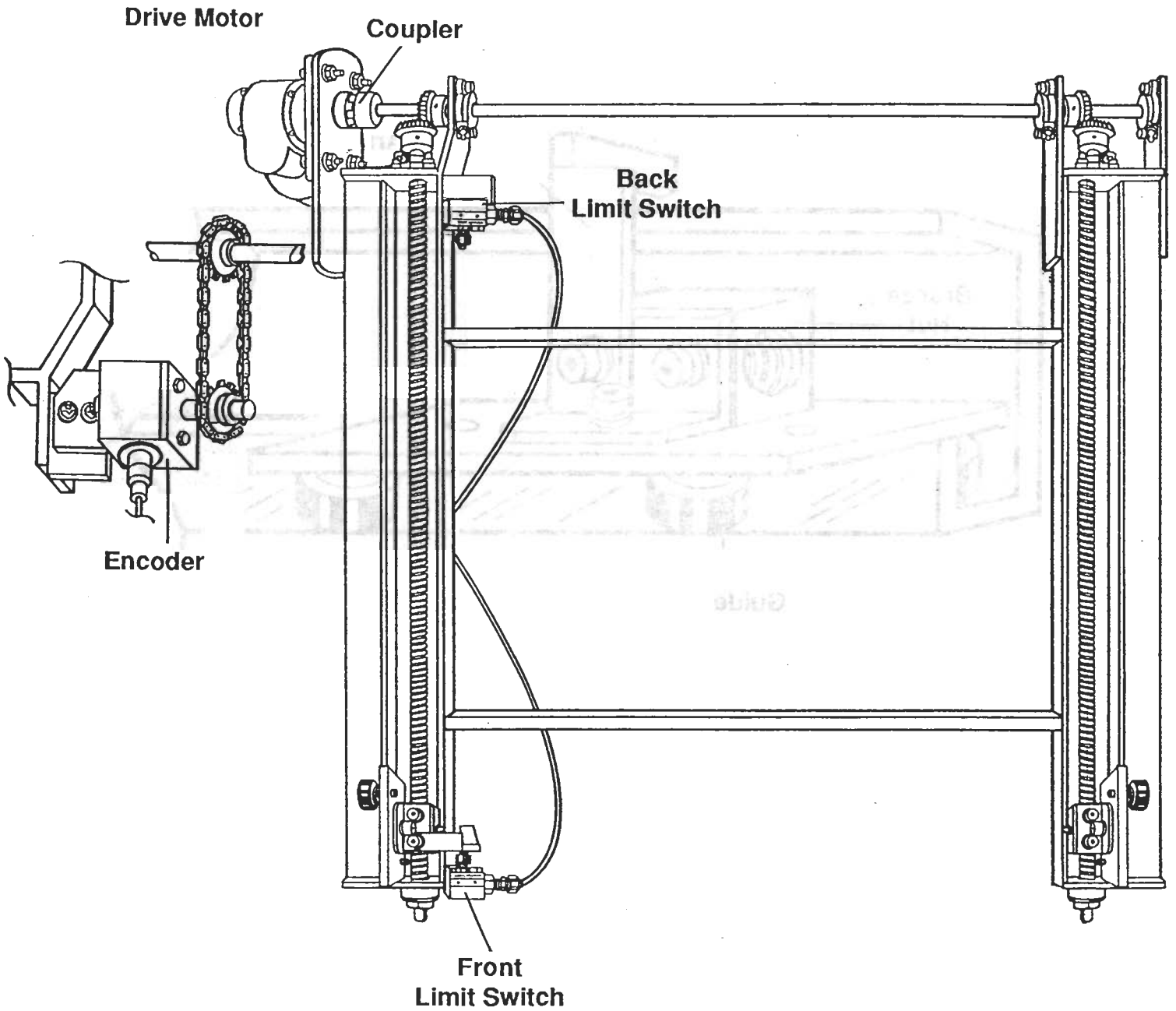

***ALL SAFETY COVERS AND GUARDS MUST REMAIN ON THE SHEAR AT ALL TIMES.**

ILLUSTRATION 3-E

BACKBAR CARRIER (View from side)

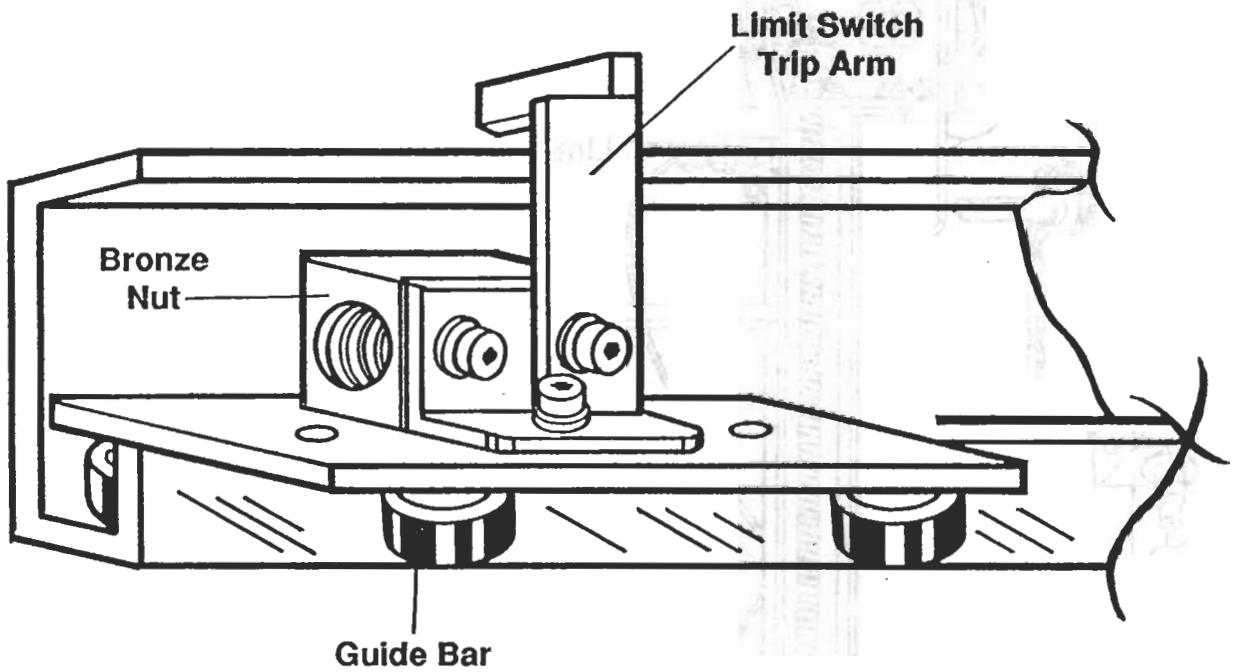

***ALL SAFETY COVERS AND GUARDS MUST REMAIN ON THE SHEAR AT ALL TIMES.**

ILLUSTRATION 3-F

10 ga. & 1/4" HYDRAULIC SCHEMATIC

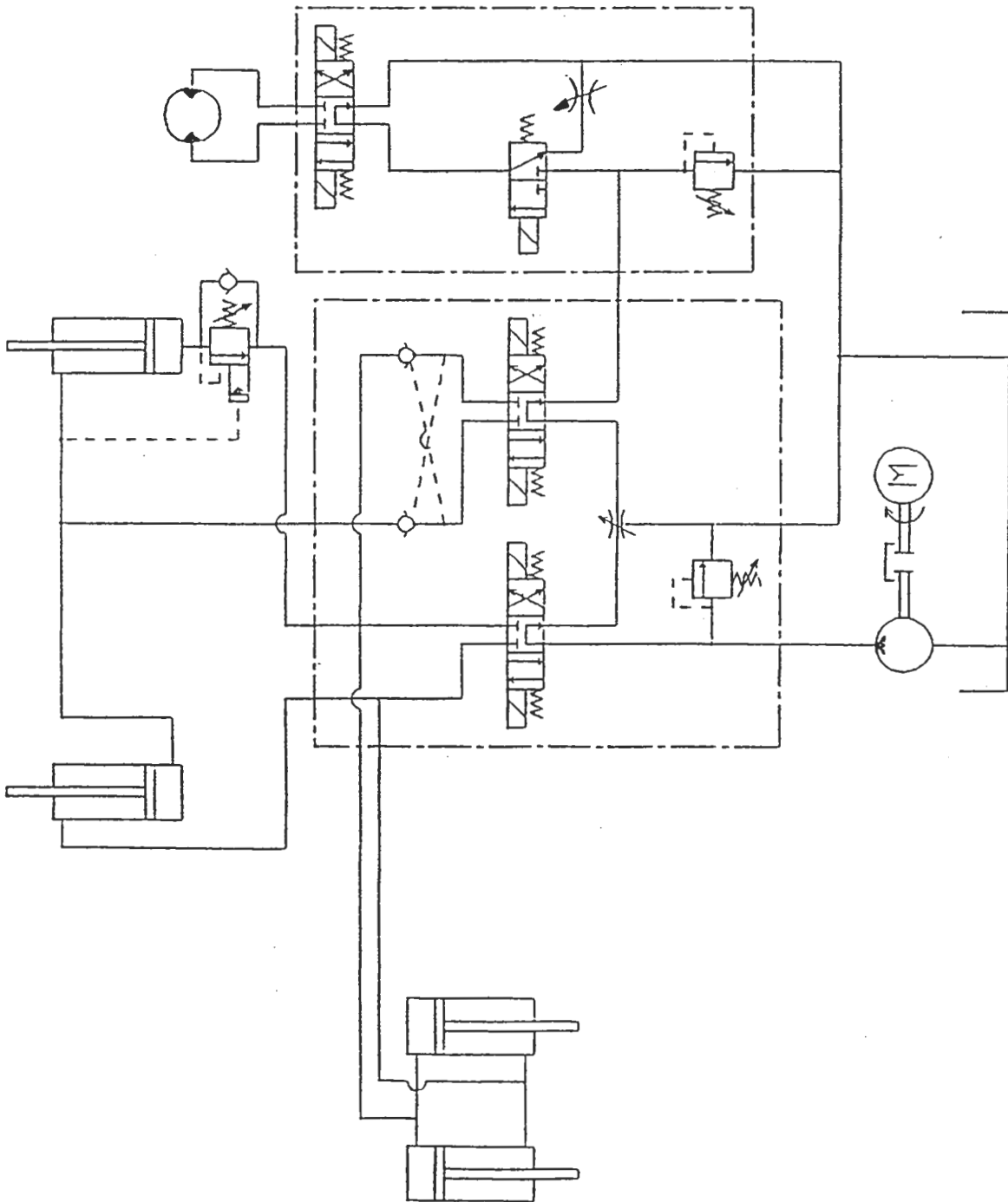

TITLE		1/4" SHEAR - HYDRAULIC DIAGRAM	
DRAWN FOR		EHA	
SCALE		NONE	
SHEET		1	
OF		1	
DATE		05-15-94	
BY		M HAND	
REV		DATE	
BY		DATE	
NUMBER		2939AA	
Electro-Hydraulic Automation Inc. Cedar Rapids, Ia 52402 319-395-0005 Fax 319-395-0200			

***ALL SAFETY COVERS AND GUARDS MUST REMAIN ON THE SHEAR AT ALL TIMES.**

SHEAR

ELEMENTARY DIAGRAM

ILLUSTRATION 3-G ELECTRICAL DIAGRAM

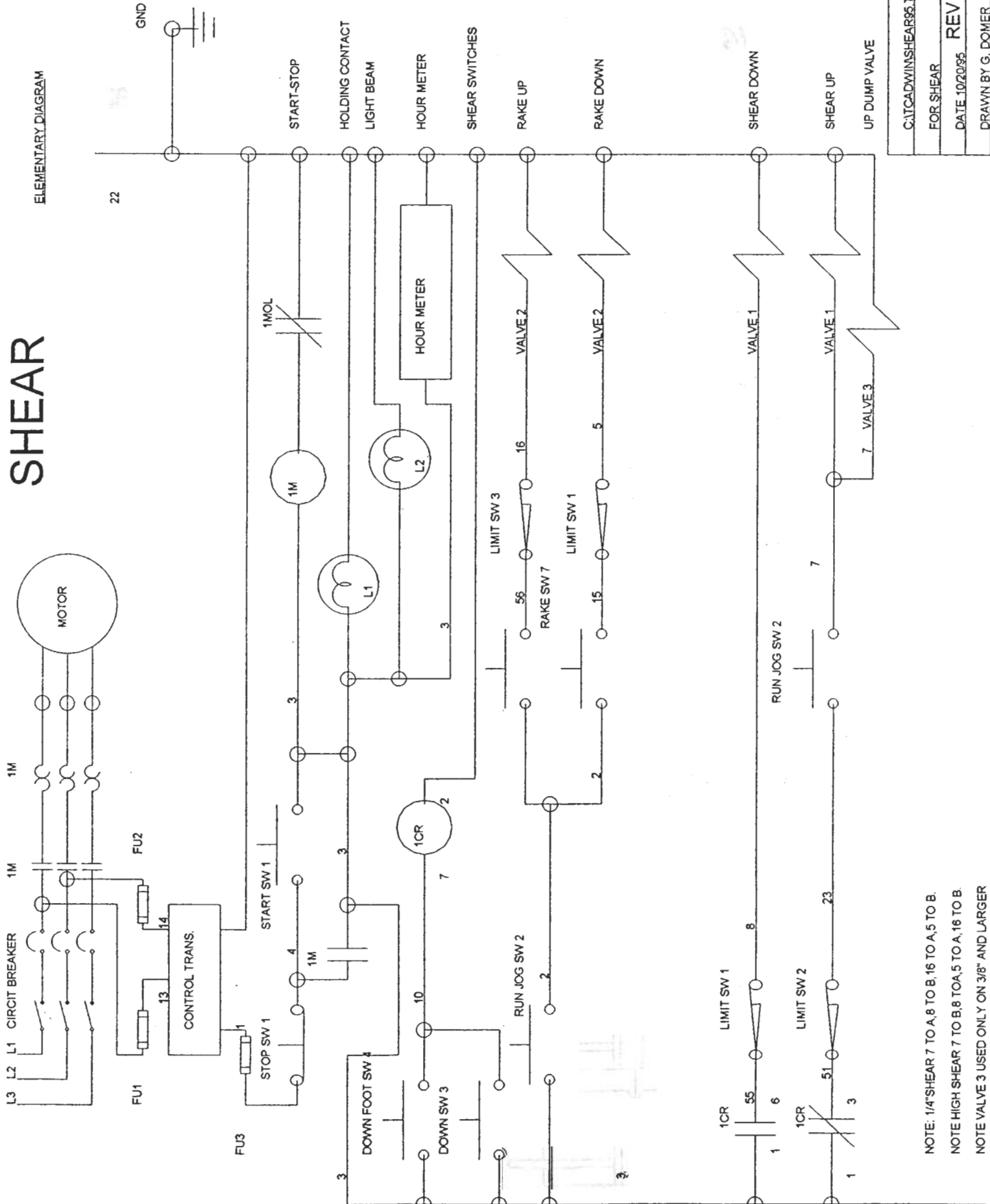

C:\TCADWIN\SHEAR95.TCW
FOR SHEAR
DATE 10/20/95 REV 4/10/96
DRAWN BY G. DOMER

***ALL SAFETY COVERS AND GUARDS MUST REMAIN ON THE SHEAR AT ALL TIMES.**

NOTE: 1/4" SHEAR 7 TO A, 8 TO B, 16 TO A, 5 TO B.
 NOTE HIGH SHEAR 7 TO B, 8 TO A, 5 TO A, 16 TO B.
 NOTE VALVE 3 USED ONLY ON 3/8" AND LARGER

POWER BACK GAGE

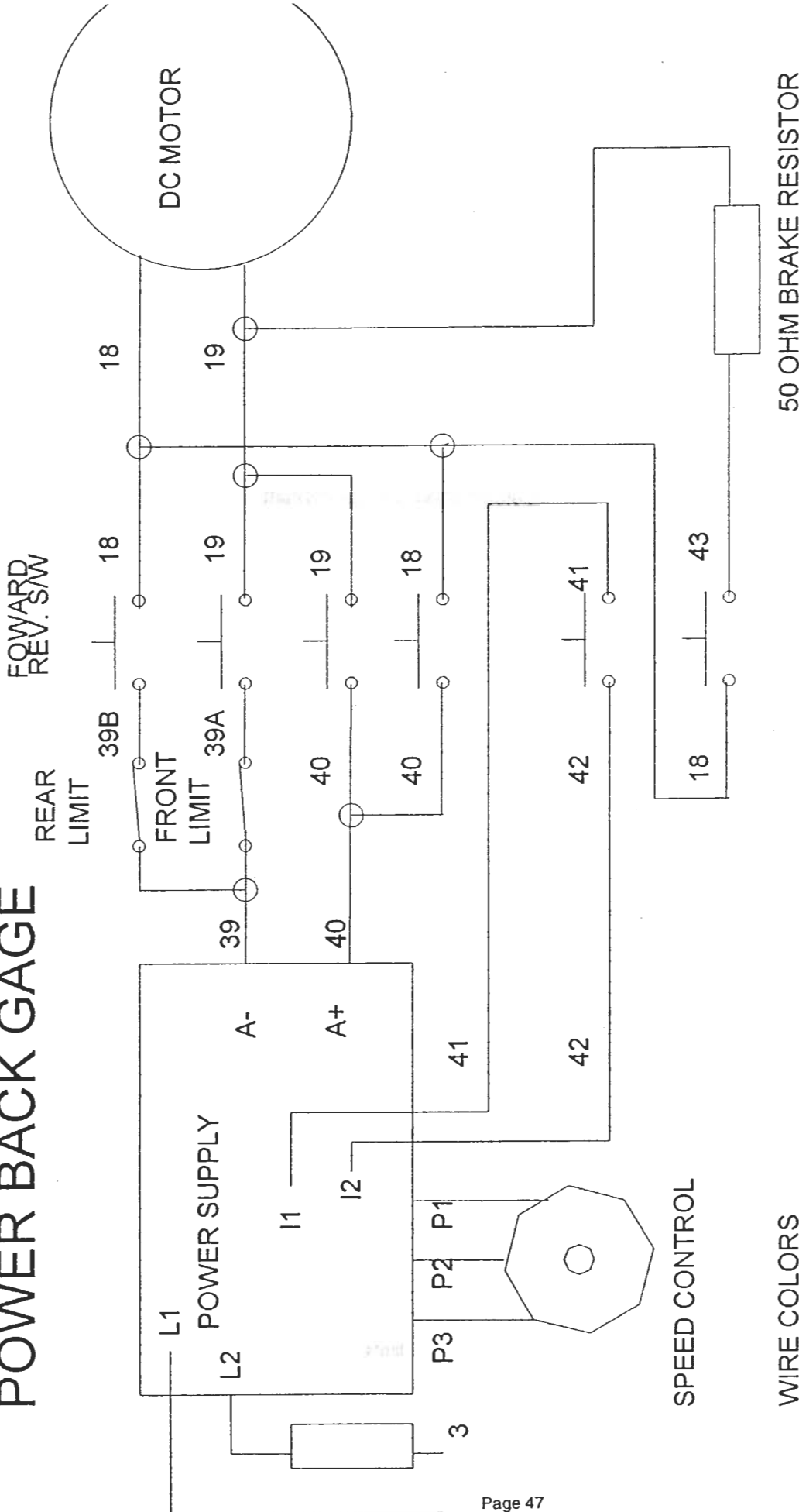

WIRE COLORS

- 18 WHITE
- 19 BLACK
- 39 RED
- 39A BLUE
- 39B ORANGE
- GND GREEN

50 OHM BRAKE RESISTOR

POWER BACK GAGE

POWBAGA.TCW

6-25-96

BY G. DOMER

***ALL SAFETY COVERS AND GUARDS MUST REMAIN ON THE SHEAR AT ALL TIMES.**



LUBRIPLATE®

MATERIAL SAFETY DATA SHEET

Section 1

PRODUCT NAME OR NUMBER

LUBRIPLATE No.930-A, No.930-2, No.930-AA, No.930-AAA

FORMULA

Inorganic Thickener, Mineral Oil and Additives

GENERIC/CHEMICAL NAME:

Petroleum Lubricating Grease

USDA AUTHORIZATION:

H-2

Section 2 - Hazardous Ingredients/Identity Information

Hazardous Components	OSHA PEL	ACGIH TLV	Other Limits Recommended	% (optional)
----------------------	----------	-----------	--------------------------	--------------

Non-hazardous

Hazardous Material Identification System (HMIS): Health - 1, Flammability - 1, Reactivity - 0

Not a Controlled Product under (WHMIS) - Canada

Special Protection: See Section 9

Section 3 - Health Hazard Data

Threshold Limit Value 5 mg/m³ for oil mist in air. OSHA Regulation 29 CFR 1910.1000

Effects of Overexposure Prolonged or repeated skin contact may cause skin irritation. Product contacting the eyes may cause eye irritation. Human health risks vary from person to person. As a precaution, exposure to liquids, vapors, mists and fumes should be minimized. This product has a low order of acute oral toxicity, but minute amounts aspirated into the lungs during ingestion may cause mild to severe pulmonary injury.

Carcinogenicity: NTP? No

IARC Monographs? No

OSHA Regulated? No

Section 4 - Emergency and First Aid Procedures

EYE CONTACT: Flush with clear water for 15 minutes or until irritation subsides. If irritation persists, consult a physician.**SKIN CONTACT:** Remove any contaminated clothing and wash with soap and warm water. If injected by high pressure under skin, regardless of the appearance or its size, contact a physician IMMEDIATELY. Delay may cause loss of affected part of the body.**INHALATION:** Vapor pressure is very low and inhalation at room temperature is not a problem. If overcome by vapor from hot product, immediately remove from exposure and call a physician.**INGESTION:** If ingested, call a physician immediately. Do not induce vomiting.

Section 5 - Fire and Explosion Hazard Data

Flash Point (Method Used) COC - 400°F Flammable Limits LEL 0.9% UEL 7.0%

Extinguishing Media Foam, Dry Chemical, Carbon Dioxide or Water Spray (Fog)

Special Fire Fighting Procedures Cool exposed containers with water. Use air-supplied breathing equipment for enclosed or confined spaces.

Unusual Fire and Explosion Hazards Do not store or mix with strong oxidants. Empty containers retain residue. Do not cut, drill, grind, or weld, as they may explode.

Section 6 - Physical/Chemical Characteristics

Boiling Point	>550°F	Specific Gravity (H ₂ O = 1)	0.94 - 0.97
Vapor Pressure (mm Hg.)	<0.01	Melting Point	Semi-solid
Vapor Density (AIR = 1)	>5	Evaporation Rate (Butyl Acetate = 1)	<0.01
Solubility in Water	Negligible		
Appearance and Odor	Smooth, tan grease with mineral oil odor.		

Section 7 - Reactivity Data

Stability	Unstable Stable X	Conditions to Avoid	N/A
Incompatibility (Materials to Avoid)	Avoid contact with strong oxidants like liquid chlorine, concentrated oxygen.		
Hazardous Decomposition or Byproducts	May form SO ₂ . If incomplete combustion, Carbon Monoxide.		
Hazardous Polymerization	May Occur Will Not Occur X	Conditions to Avoid	N/A

Section 8 - Spill or Leak Procedures

Steps to be taken in case material is released or spilled
 Scrape up grease, wash remainder with suitable petroleum solvent or add absorbent. Keep petroleum products out of sewers and water courses. Advise authorities if product has entered or may enter sewers and water courses.

Waste disposal method
 Assure conformity with applicable disposal regulations. Dispose of absorbed material at an approved waste disposal facility or site.

SARA/TITLE III, Section 313 Status - Zinc Compounds - <8%

Section 9 - Special Protection Information

Respiratory Protection (Specify type)	Normally not needed		
Ventilation	Local Exhaust Mechanical (General)	Used to capture fumes and vapors	Special N/A Other N/A
Protective Gloves	Use oil-resistant gloves, if needed.	Eye Protection	If chance of eye contact, wear goggles.
Other Protective Equipment	Use oil-resistant apron, if needed.		

Section 10 - Special Precautions

Precautions to be taken in handling and storing
 Keep containers closed when not in use. Do not handle or store near heat, sparks, flame, or strong oxidants.

Other Precautions
 Remove oil-soaked clothing and launder before reuse. Cleanse skin thoroughly after contact.

The above information is furnished without warranty, expressed or implied, except that it is accurate to the best knowledge of Fiske Brothers Refining Company. The data on these sheets relates only to the specific material designated herein. Fiske Brothers Refining Company assumes no legal responsibility for use or reliance upon this data.

00258

HMIS HAZARD RATING

LEAST	0	HEALTH	1
SLIGHT	1	FIRE	1
MODERATE	2	REACTIVITY	0
HIGH	3	PERSONAL	
EXTREME	4	PROTECTION	B

MATERIAL SAFETY DATA SHEET

The information contained herein is based on data considered accurate. However, no warranty is expressed or implied regarding the accuracy of these data or the results to be obtained from the use thereof. Vendor assumes no responsibility for injury to vendee or third persons proximately caused by the material if reasonable safety procedures are not adhered to as stipulated in the data sheet. Additionally, vendor assumes no responsibility for injury to vendee or third persons proximately caused by abnormal use of the material even if reasonable safety procedure are followed. Furthermore, vendee assumes the risk in his use of the material.

SECTION 1:

CHEMICAL NAME: Mixture

CHEMICAL FAMILY: Petroleum Hydrocarbon

MSDS #5000

SECTION 2-A: PRODUCT INGREDIENTS

NO.	COMPOSITION	CAS NUMBER	%
P	Industrial Hydraulic and Turbine Oil	MIXTURE	100
1.	Sol. Ref., Heavy Paraffinic Distillate	64742-54-7	
2.	Light Napthenic Hydrotreated Distillate	64742-53-6	
3.	Heavy Napthenic Hydrotreated Distillate	64742-52-5	
4.	Deasphalted Residuum	64742-95-3	
5.	Sol. Ref., Saturated Paraffinic Distillate	64742-65-0	

SECTION 2-B: ACUTE TOXICITY DATA

NO.	ACUTE ORAL LD50	ACUTE DERMAL LD50	ACUTE INHALATION LCS
-----	-----------------	-------------------	----------------------

P Not Available

SECTION 3: HEALTH INFORMATION

TARGET ORGANS

The health effects noted below are consistant with requirements under the OSHA hazard communication standard (29 CFR 1910.1200).

EYE CONTACT: Lubricating oils are generally considered no more than minimally irritating to the eyes.

SKIN CONTACT: Lubricating oils are considered no more than mildly irritating to the skin. Prolonged and repeated contact may lead to various skin disorders such as dermatitis, oil acne or folliculitis.

INHALATION: Inhalation of vapors (generated at high temperatures only) or oil mist from this product may cause mild irritation of the upper respiratory tract.

INGESTION: Lubricating oils are generally considered no more than slightly toxic if swallowed.

SIGNS AND SYMPTOMS: Irritation as noted above.

AGGRAVATED MEDICAL CONDITIONS: Preexisting skin and respiratory disorders may be aggravated by exposure to this product.

SECTION 4: OCCUPATIONAL EXPOSURE LIMITS

OSHA

NO.	PEL/TWA	PEL/CEILING	TLV/TWA	TLV/STEL
P	NONE	NONE	NONE	NONE
1.	5MG/M3*	NONE	5MG/M3*	10MG/M3*
2.	5MG/M3*	NONE	5MG/M3*	10MG/M3*
3.	5MG/M3*	NONE	5MG/M3*	10MG/M3*
4.	5MG/M3*	NONE	5MG/M3*	10MG/M3*
5.	5MG/M3*	NONE	5MG/M3*	10MG/M3*

CARCINOGENICITY: LISTED BY: IARC = no OSHA = no NPT = no

SECTION 5: EMERGENCY AND FIRST AID PROCEDURES

EYE CONTACT: Flush with water for 15 minutes while holding eyelids open. Get medical attention.

SKIN CONTACT: Remove contaminated clothing and wipe excess off. Wash with soap and water or a waterless hand cleaner followed by soap and water. If irritation occurs, get medical attention.

INHALATION: Remove victim to fresh air and provide oxygen if breathing is difficult. Get medical attention.

INGESTION: Do not induce vomiting. In general no treatment is necessary unless large quantities of product are ingested. However, get medical help.

NOTE TO PHYSICIAN: In general, emesis induction is unnecessary in high viscosity, low volatility products, I.E., most oils and greases.

SECTION 6: SUPPLEMENTAL INFORMATION

None Identified.

SECTION 7: PHYSICAL DATA

BOILING POINT	MELTING POINT	VAPOR PRESSURE
(°C) >300	(°C) N.A.	(mmHg) N.A.

SPECIFIC GRAVITY (H2O = 1) .87-90	% VOLATILE BY VOLUME <.01	VAPOR DENSITY (AIR = 1) N.A.
--------------------------------------	------------------------------	---------------------------------

SOLUBLE IN WATER Negligible

EVAPORATION RATE (BUTYL ACETATE = 1) N.A.

NOTES:
N.A.=NOT AVAILABLE
N.D.= NOT DETERMINED
N.E.=NOT ESTABLISHED

APPEARANCE AND ODOR: Medium colored liquid - Mild hydrocarbon odor.

SECTION 8: FIRE AND EXPLOSION HAZARDS

FLASH POINT AND METHOD: COC oC >220	FLAMMABLE LIMITS % VOLUME IN AIR:	LOWER N.A.	UPPER N.
--	--------------------------------------	---------------	-------------

EXTINGUISHING MEDIA: Use water fog, foam, dry chemical or CO2. Do not use a direct stream of water. Product will float and can be reignited on surface of water.

SPECIAL FIRE FIGHTING PROCEDURES AND PRECAUTIONS: Material will not burn unless preheated. Do not enter confined fire-space without full bunker gear (helmet with face shield, bunker coats, gloves and rubber boots). Including a positive-pressure NIOSH-approved self-contained breathing apparatus. Cool fire exposed containers with water.

UNUSUAL FIRE AND EXPLOSION HAZARDS:

SECTION 9: REACTIVITY

STABILITY -	UNSTABLE	STABLE X
HAZARDOUS POLYMERIZATION -	MAY OCCUR	MAY NOT OCCUR X

CONDITIONS AND MATERIALS TO AVOID: Avoid heat, open flames and oxidizing materials.

HAZARDOUS DECOMPOSITION PRODUCTS: Thermal decomposition products are highly dependent on the combustion conditions. A complex mixture of airborne solid, liquid, particulates and gases will evolve when this material undergoes pyrolysis or combustion. Carbon monoxide and other unidentified organic compounds may be formed upon combustion.

SECTION 10: EMPLOYEE PROTECTION
PERSONAL PROTECTIVE EQUIPMENT:

RESPIRATORY PROTECTION: If exposure may or does exceed occupational exposure limits (Section IV) use a NIOSH-approved respirator to prevent overexposure. In accord with 29 CFR 1910.134 use either an atmosphere supplying respirator or an air-purifying respirator for organic vapors and particulates.

PROTECTIVE CLOTHING: Wear chemical resistant gloves and other protective clothing as required to minimize skin contact. Wear safety goggles to avoid eye contact. Test data from published literature and/or clothing manufacturers indicate the best protection is provided by nitrile gloves. Follow good industrial hygiene practices.

OTHER PROTECTIVE EQUIPMENT:

VENTILATION:

LOCAL:

MECHANICAL:

SECTION 11: ENVIRONMENTAL PROTECTION

SPILL OR LEAK PROCEDURES: May burn although not readily ignitable. Use cautious judgment when cleaning up large spills. ***LARGE SPILLS*** Wear respirator and protective clothing as appropriate. Shut off source of leak if it is safe to do so. Dike and contain. Remove with vacuum trucks or pump to storage salvage vessels. Soak up residue with an absorbent such as clay, sand, or other suitable materials. Dispose of properly. Flush area with water to remove trace residue. ***SMALL SPILLS*** Take up with an absorbent material and dispose of properly.

WASTE DISPOSAL: Place in an appropriate disposal facility in compliance with local regulations.

ENVIRONMENTAL HAZARDS: This product is classified as an oil under section 311 of the Clean Water Act. Spills entering (A) surface waters or (B) any water courses or sewers entering/leading to surface waters that cause a sheen must be reported to the National Response Center.
800-424-8602

SECTION 12: SPECIAL PRECAUTIONS

Minimize skin contact. Wash with soap and water before eating, drinking, smoking or using toilet facilities. Launder contaminated clothing before reuse. Properly disposed of contaminated leather articles, including shoes, that cannot be decontaminated.

SECTION 13: TRANSPORTATION REQUIREMENTS

~~DOT CLASSIFICATIONS: Not hazardous by D.O.T. regulations.~~

SECTION 14: OTHER REGULATORY CONTROLS