

Save Time! Save Money!

All 3000 Series Parts Numbers are Complete "Ready to Use" Assemblies.

Ref	Description	Model IM865 P/N	Model IM1065 P/N	Model IM1265 P/N
1	Tube, Cam	4403	4404	4405
2	F-Bar, w/SS/Tape Rule	3676	3677	3678
3	Hinge, Front	3681	3682	3683
4	Hinge, Fixed Rear	4520	4521	4522
5	Rail, Base	4132	4133	4134
6	Strip, Stainless Steel Edge*	4792	4793	4794
7	Hinge Pin	4062	4063	4064
8	Wear Strip	4734	4735	4736

*Can Ship UPS in 2 Pieces

Call For IM665 & IM1465 Parts

Parts For All Models

Ref	Part Name	P/N
9	Rule, Tape Inches/Metric	4765
10	Handle, Bending	4810
11	Post, Handle (2 ea)	3906
12	Handle, Locking	4805
13	Bracket, Locking Handle	4107
14	Handle, Carrying	3686
15	Cam, Locking	4801
16	Pads, Wedge UHMW (10 ea)	3574
17	Bearing, Cam Tube (2 ea)	3901
18	Springs, Coil 3/4 x 1 3/4" (4 ea)	3902
19	Casting, Pivot Arm	4462B
20	Casting, Base C Clamp	4870
21	Material Stop Assembly	3687
22	Spring Pivot	4767

Optional Accessories

TrimCutter™	Part No. 3017	NailHawg™	Part No. NH25/NH31
-------------	---------------	-----------	--------------------



Don't forget the one accessory that literally cuts your labor in half. TrimCutter™ is the perfect Add-On, paying for itself in as little as one job.



Available in 25 and 31 inch swaths, NailHawg™ gets all the metal debris and uses a unique toe/hand release to collect and dispose of nails where ever you want them.

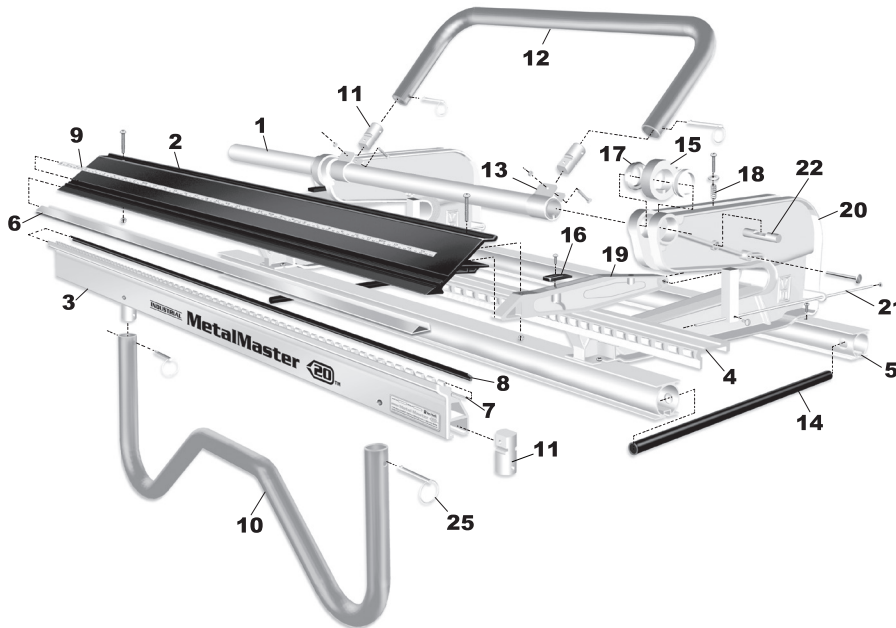

Tune-Up Kit No. 3914

Ref	Part Name	P/N
8	Wear Strip	4737
16	Pads, Wedge UHMW	3574
17	Bearing, Cam Tube	3901
18	Springs, Coil 3/4 x 1 3/4"	3902
25	Faspins	3655



Master Stand™ EZ-Go™ PN 3034B

Ref	Description	P/N
23	Platform Assembly	3033B
24	Stand	USA2EZ