

TIN KNOCKER TK 16 GA. POWER FLANGER



INSTRUCTIONS & PARTS DIAGRAM

RED RIVER MACHINERY
1-800-729-0759
www.redrivermachinery.com

WARRANTY

All new machines are sold with a one-year limited warranty, on factory defective parts. The warranty is limited to the original user. TAAG Machinery Co. at its option, will repair, replace or refund the purchase price of any part, tool or machine that fails during the warranty period. TAAG Machinery Co. will pay normal shipping charges for replacement parts. After 90 days from date of purchase, all express or overnight delivery charges are the responsibility of the customer. Purchaser must deliver to TAAG Machinery Co., at the address below, any written claim, with proof of original purchase. Replacement parts will be invoiced to purchaser and credit issued when the failed part is delivered to TAAG Machinery Co. Removal, reinstallation or replacement parts shall be at purchasers' / user's expense. Failure due to improper use of the machine voids the warranty.

NOTE:

1. This machine has been tested and adjusted prior to shipment, but can and often does require readjustment due to vibration and bouncing during transport. Following the procedures described within can easily do readjustment. These are procedures with which you, as a user, should be familiar, as you will use them repeatedly over the life use of the machine. If you have difficulty in performing these procedures, we are here to support you.
2. Opening rolls (for Philipsburg Lock) are consumable items and not subject to warranty

SPECIFICATIONS

Maximum Capacity	16 gauge Aluminum, copper, stainless steel, brass
Shipping weight	635 lbs
Motor	0.75 HP
Dimensions	36" x 28" x 48"

SAFETY PRECAUTIONS

1. Keep the work area well-lit and uncluttered to avoid accidents.
2. Turn off machine to clean. Do not use compressed air for cleaning debris from yourself or the machine. Remove debris and grit from machine with a rake or brush – not your hands.
3. Only authorized and trained personnel should operate the machine.
4. Thoroughly read and understand the Operator's Manual as well as the warnings and instructions mounted on the machine.
5. Notify your supervisor whenever you feel there is a hazard involving the equipment or the performance of your job.
6. Report all injuries or illness, regardless of severity, to your supervisor.
7. Do not place speed above safety.
8. Never use this machine for anything other than its intended purpose. Use the proper tool and equipment for the task.
9. Do not remove, paint over, alter, or deface any machine-mounted warning and instruction plates and signs.
10. Do not operate the machine more than its rated capacity.
11. Beware of protruding machine elements or assemblies. Avoid any pinch-points created by the movement of the machine's components.
12. Do not override the safety features of the equipment or remove any guarding.
13. Use proper Personal Protective Equipment (PPE) while operating machine.

RECEIVING THE MACHINE

- Upon receipt and before signing the Bill of Lading carefully examine the machine for damage that may have occurred during shipping.
- Be certain you have two handles.
- Any loss or damage should be noted in detail on the delivery receipt and reported to your distributor immediately.
- Free replacement from TK International is dependent upon the notation and the Bill of Lading on delivery slip.

INSTALLING THE MACHINE

- If the machine is shipped on a pallet, remove the machine from the pallet.
- Ensure that machine is reasonably level between all four mounting points.
- Machine must be securely mounted to the ground with bolts.

OPERATION

- adjust the dial so that the flanger applies adequate pressure to the work.
- Adequate pressure will result in square flanges.
- Too much pressure on the work will result in “buckled” flanges.
- Not enough pressure on the work will result in irregular or curved flanges.
- Use less pressure for soft metals like aluminum or copper and more pressure for harder metals like brass or stainless steel.
- Keep the knurl oiled to prevent galvanized deposits from forming.

Full Assembly Parts Diagram

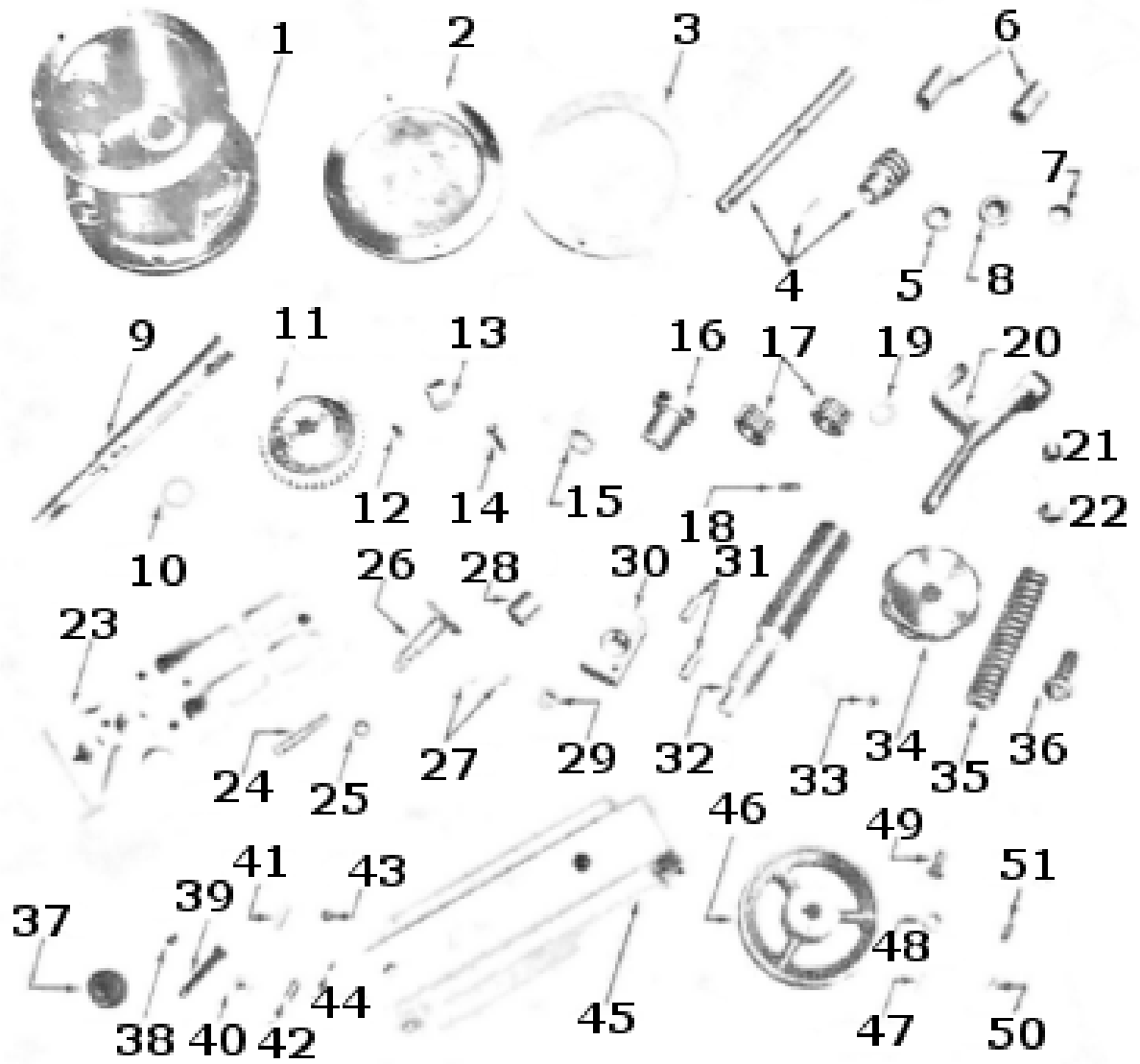

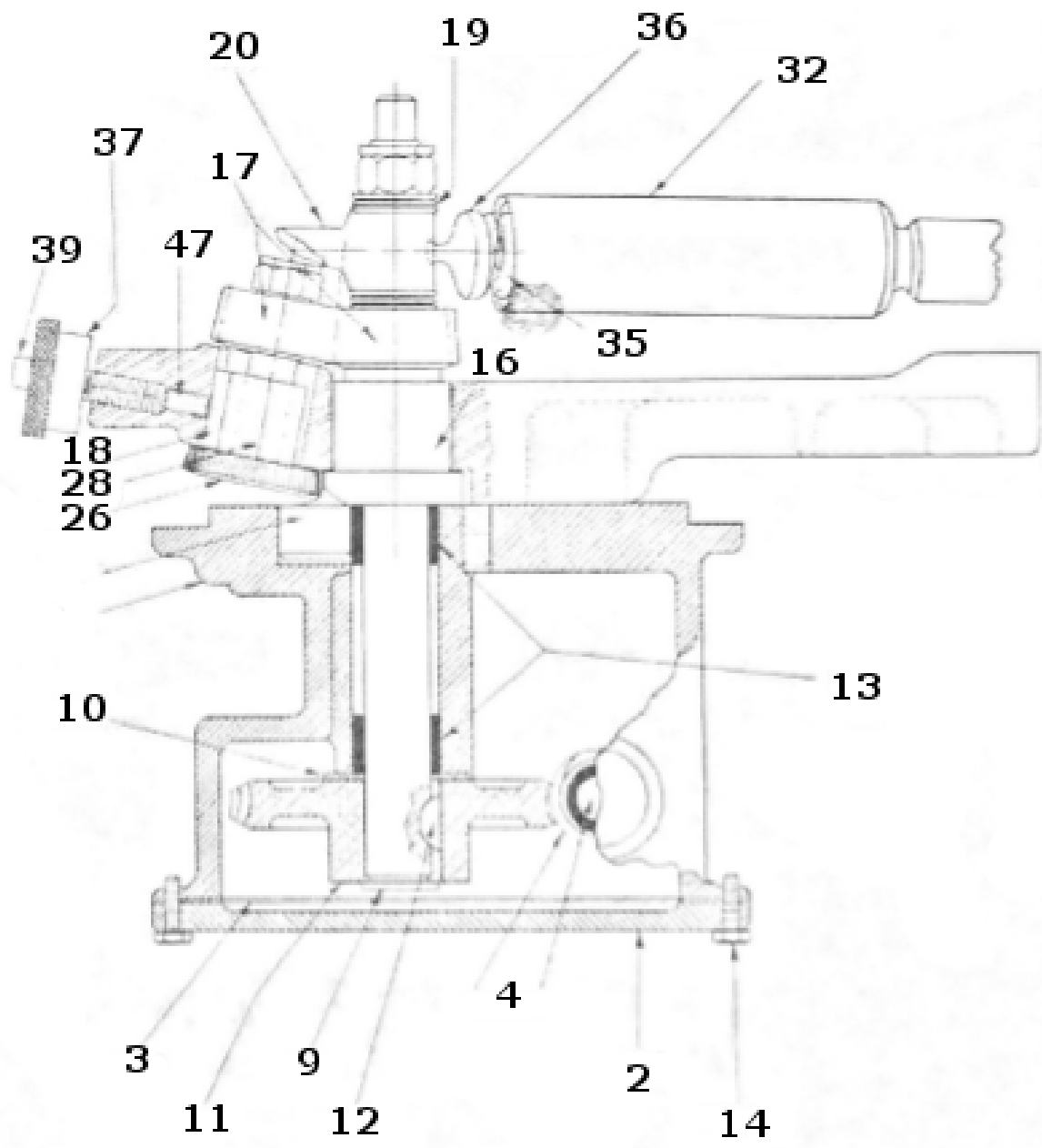

Parts List

Fine No	Part No	QTY	Name
1	PF001	1	
2	PF002	1	
3	PF003	1	
4	PF004	1	
5	PF005	1	
6	PF006	2	
7	PF007	1	
8	PF008	1	
9	PF009	1	
10	PF010	1	
11	PF011	1	
12	PF012	3	
13	PF013	2	
14	PF014	5	
15	PF015	1	
16	PF016	1	
17	PF017	2	
18	PF018	1	
19	PF019	2	
20	PF020	1	
21	PF021	3	
22	PF022	1	
23	PF023	1	
24	PF024	3	
25	PF025	7	
26	PF026	1	
27	PF027	2	
28	PF028	1	
29	PF029	1	
30	PF030	2	
31	PF031	1	
32	PF032	1	
33	PF033	1	
34	PF034	1	
35	PF035	1	
36	PF036	1	
37	PF037	1	
38	PF038	1	
39	PF039	1	

40	PF040	1	
41	PF041	1	
42	PF042	1	
43	PF043	1	
44	PF044	1	
45	PF045	1	
46	PF046	1	
47	PF047	1	
48	PF048	4	
49	PF049	4	
50	PF050	4	
51	PF051	1	