

GMC Power Slip Roll

MODEL: PSR-5016

50" x 16 Ga.



Operation Manual

I Main specification

NO.	MODEL		PSR-5016
1	Max rolling width	40" (1010mm)	50" (1280mm)
2	Max rolling thickness	16gauge(1.5mm)	16gauge(1.5mm)
3	Rolling diameter	2"(50mm)	3"(75mm)
4	Rotate speed	22rpm	22rpm
5	Motor Power	0.75kw	0.75kw
6	Overall dimension	1285x520x935(mm)	1650x520x960(mm)
7	Weight	350kg	400kg

II Machinery general safety warnings

1. Misuse of this machine can cause serious injury. For safety, machine must be set up, used and serviced properly. Read, understand and follow instructions in the operator's and parts manual which was shipped with your machine.
2. Wear proper apparel. No loose clothing or jewelry which can get caught in moving parts. Gloves and rubber soled footwear is recommended for best footing.
3. Do not overreach. Failure to maintain proper working position can cause you to fall into the machine or cause your clothing to get caught — pulling you into the machine.
4. Keep guards in place and in proper working order. Do not operate the machine with guards removed.
5. Avoid dangerous working environments. Do not use stationary machine tools in wet or damp locations. Keep work areas clean and well lit.
6. Avoid accidental starts by being sure the start switch is "OFF" before plugging in the machine.
7. Never leave the machine running while unattended. Machine shall be shut off whenever it is not in operation.
8. Disconnect electrical power before servicing. Whenever changing accessories or general maintenance is done on the machine, electrical power to the machine must be disconnected before work is done.
9. Machinery must be anchored to the floor.
10. Use the right tool. Don't force a tool or attachment to do a job it was not designed for.
11. Keep hands in sight and clear of all moving parts and rolling surfaces.
12. All visitors should be kept at a safe distance from the work area. Make workshop completely safe by using padlocks, master switches, or by removing starter keys.
13. Know the tool you are using — its application, limitations, and potential hazards.
14. General Electrical Cautions :This machine should be grounded in accordance with the National Electrical Code and local codes and ordinances. This work should be done by a qualified electrician. The machine should be grounded to protect the user from electrical shock.

III INSTRUCTION

1. HOW TO FORM CIRCLES IN JUST TWO PASSES.- Length of material necessary to form the desired size circle is the first consideration in circle forming. To determine approximate length of material needed, use the formula $C=\pi D$. C is Circumference. π equals 3.1417. D is Diameter. For example, to find the length of material needed(C or Circumference) to form a circle 4" in diameter multiply 3.1417 by 4". Result –12.5667 is the circumference of approximate length of material needed. Cut a few pieces of material to this length for test forming. Material may have to be lengthened or shortened depending upon results of the test forming run.

2. TO ADJUST ROLLER- for material thickness, loosen the thumb screw to the right of the adjusting screws. Turn the adjusting screws to raise or lower the lower pinch roll. Insert the material between the rolls from the front of the machine and set rolls so the material fits tightly. Retighten the thumb screws and remove the material from between the rolls.

3. NO EXACT FORMULA- can be followed when making this adjustment because material "spring back" varies with the kind of material being formed. Only by test forming several pieces can the correct adjustments be obtained. Rolls must be adjusted exactly parallel or the material will spiral during the rolling process.

4. TO OPERATE ROLLER- after diameter adjustments have been made, insert material from front of roller and turn operating handle in a clockwise direction until about half of the material has passed through the rolls; if roller is power operated make sure that the upper pinch roll is rotating in a counter clockwise direction. Then, while feeding material, raise the idler roll. Continue turning until a half circle has been formed. It is important that you operate the roller while engaging the cam lever. For if the cam lever is engaged while the rolls are not turning, a noticeable flat spot or line will be formed across the width of the material.

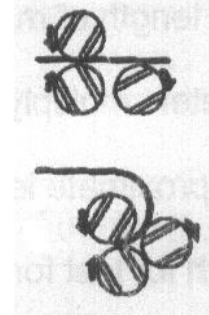

5. AFTER HALF CIRCLE- has been formed, reinsert the formed end of the material in to the roller(as follows illustrated) and turn operating handle in a clockwise direction to form a complete circle. If roller is power operated, turn switch in a position that allows the upper pinch roll to rotate in a counter clockwise direction.



6. FRONT AND REAR ADJUSTMENT SCREWS- The four adjustment screws (two

located in the front and two located in the rear) have been built into the left and right side frames.

The two front adjusting screws enable the operator to raise or lower the pinch roll, so that the correct gap between the upper and lower pinch roll may be obtained to feed the desired stock in to the machine.

The left and right rear adjusting screws assist the operator in raising or lowering the idler roll which determines the degree of bend in the stock that is being fed through the machine. The right and left side frames are each equipped with a scale to aid the operator in determining.

7. TO REMOVE THE FORMED PART- lift clamp handle and slide the support lever handle to the right. The upper pinch roll will rise. Slide the material off roll. If the material is not long enough or if the formed part is not the proper diameter, additional samples will have to be made. Thousands of identical parts can be precisely duplicated when proper adjustment of the roller have been made.



8. REVERSE ROLLING CIRCLES- the same diameter as the diameter of the rolls and slightly larger, can be formed with the Roller in just one pass. To make the adjustment for material thickness and to determine the length of material needed, see the instructions given under "How To Form Circles In Just Two Passes".

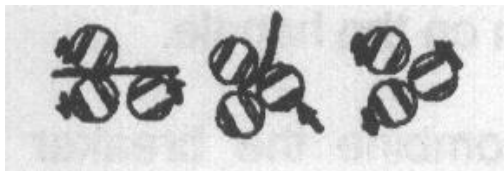

IV Electric System

1, Preparation :The consumer should prepare a 10A power switch. Connect 3x4 mm² + 1x4mm² yellow/green with the power switch. The earth-line should be connected with the earth-plate.

2, Operation of the machine

Combine the breaker in the electric appliance box and turn right the power switch. At this time the indicator lighted, which means the machine had been connected with power correctly. Pedal down the right starting pedal, the machine rolls clockwise continuously until loosen the pedal. Pedal down the left starting pedal, the machine rolls on the contrary of the above direction. If there is some wrong with the machine, push the lash-up switch on the handle to stop the machine. After the trouble is solved, turn off the switch to work.

3, Maintenance of the machine

The machine has a compact structure. It is easy to be operated and maintained. Some problems maybe exist as follows:

- 1) The indicator lights, the machine can't work when pedal down the starting pedal, then turn off the lash-up switch on the handle.
- 2) The indicator doesn't light, then combine the breaker in the electric appliance box.
- 3) The indicator lights and the spindle works, but motor doesn't work, that means the connecting wire is loose or disconnected.
- 4, Electric principle drawing (refer to the attached drawing)
- 5, Main electric appliance list

No.	Symbol	Name	Quantity
1	LW	Power switch	1
2	QF	Breaker	2
3	TC	Transformer	1
4	KM	Alternating contactor	2
5	EL	Indicator light	2
6	TA	Lash-up switch	1
7	M	Motor	1

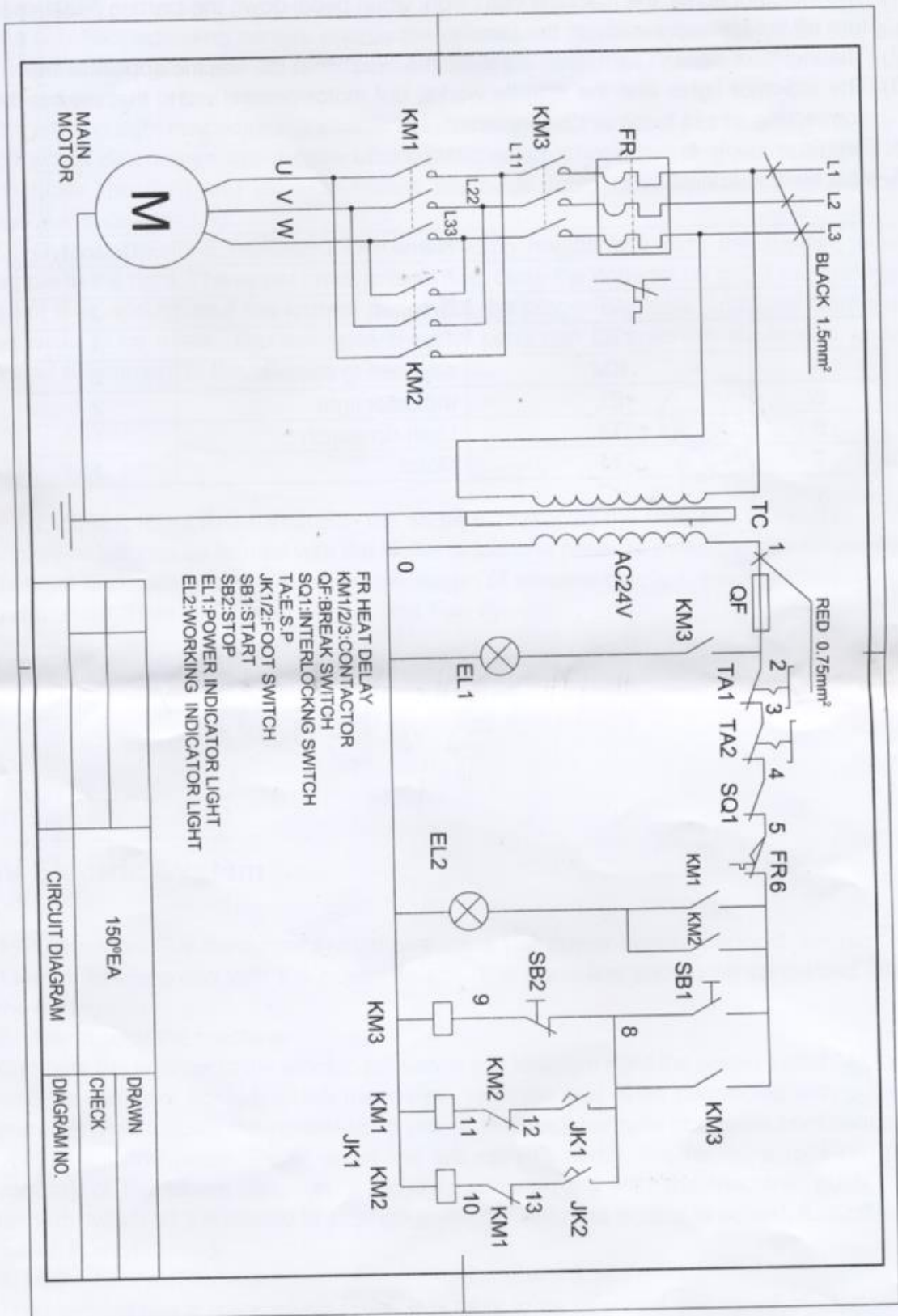

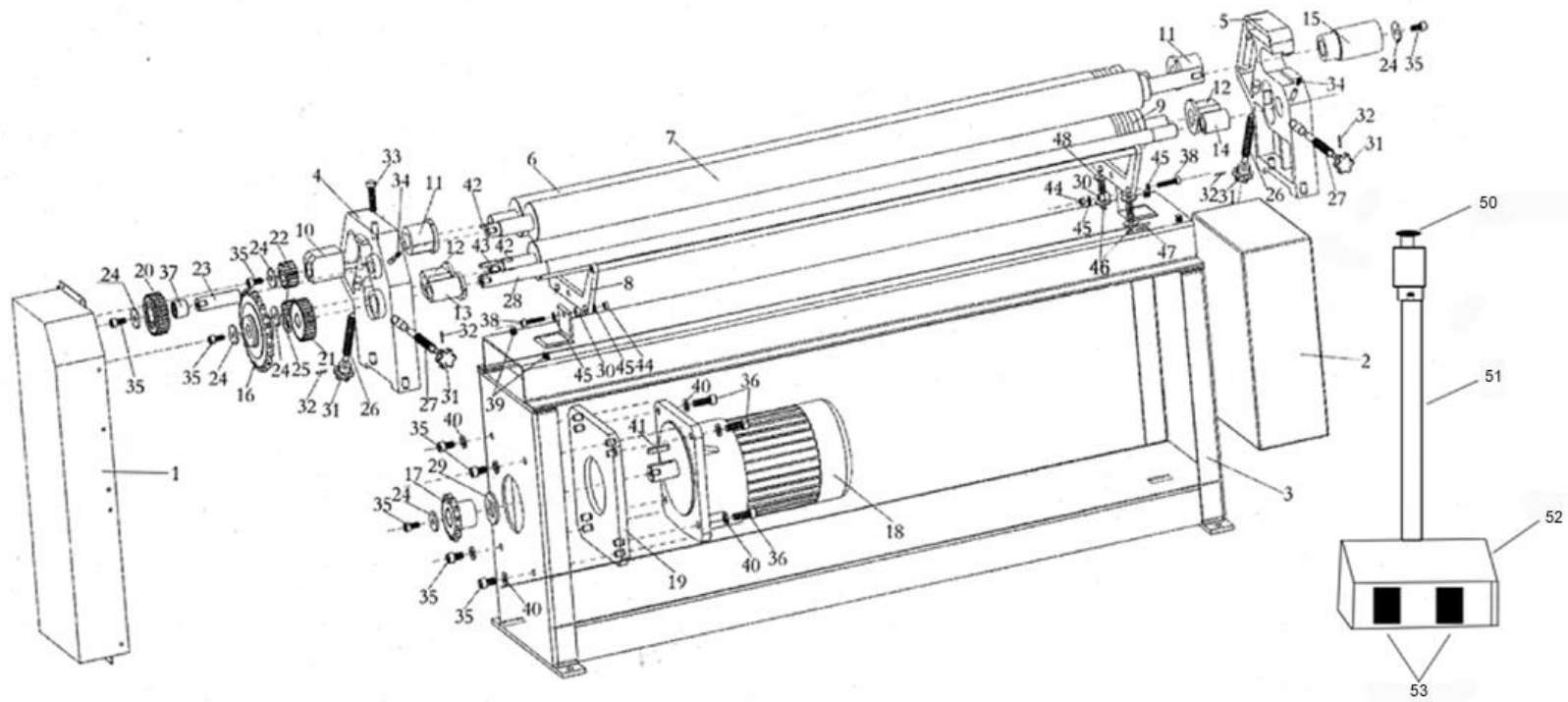

Parts List of ESR1300X1.5

Part #	Description	Q'ty	Part #	Description	Q'ty
1	Protecting Cover	1	28	Transmission Shaft	1
2	Electric Box	1	29	Washer	1
3	Stand Body	1	30	Bushing	2
4	Left Frame	1	31	Handle	4
5	Right Frame	1	32	Pin	4
6	Adjusting Roller	1	33	Bolt M12X50	1
7	Driver Roller	1	34	Fixing Screw M8x20	2
8	Protecting Bracket	1	35	Screw M10x20	5
9	Auxiliary Roller	1	36	Screw M12X35	4
10	Square Bushing	1	37	Bearing	1
11	Supporting Bushing	2	38	Screw M8X40	2
12	Supporting Bushing	2	39	Bolt M12X25	4
13	Left Bushing for Driver Roller	1	40	Flat Washer	8
14	Right Bushing for Driver Roller	1	41	Key 10X45	1
15	Sleeve for Handle	1	42	Key 6X25	3
16	Large Chain Wheel	1	43	Key 6X40	1
17	Small Chain Wheel	1	44	Nut M8	2
18	Motor	1	45	Flat Washer	4
19	Link Plate for Motor	1	46	Worm Rod	2
20	Gear	1	47	Lock Spring	2
21	Driver Gear	1	48	Flat Washer	4
22	Driven Gear	2	49	Chain	1
23	Gear Wheel Shaft	1	50	Emergency switch	1
24	Washer	6	51	Pole	1
25	Adjusting Washer	1	52	Box cover	1
26	Bolt for Adjusting Roller	2	53	Pedal switch	1
27	Bolt for Auxiliary Roller	2			