

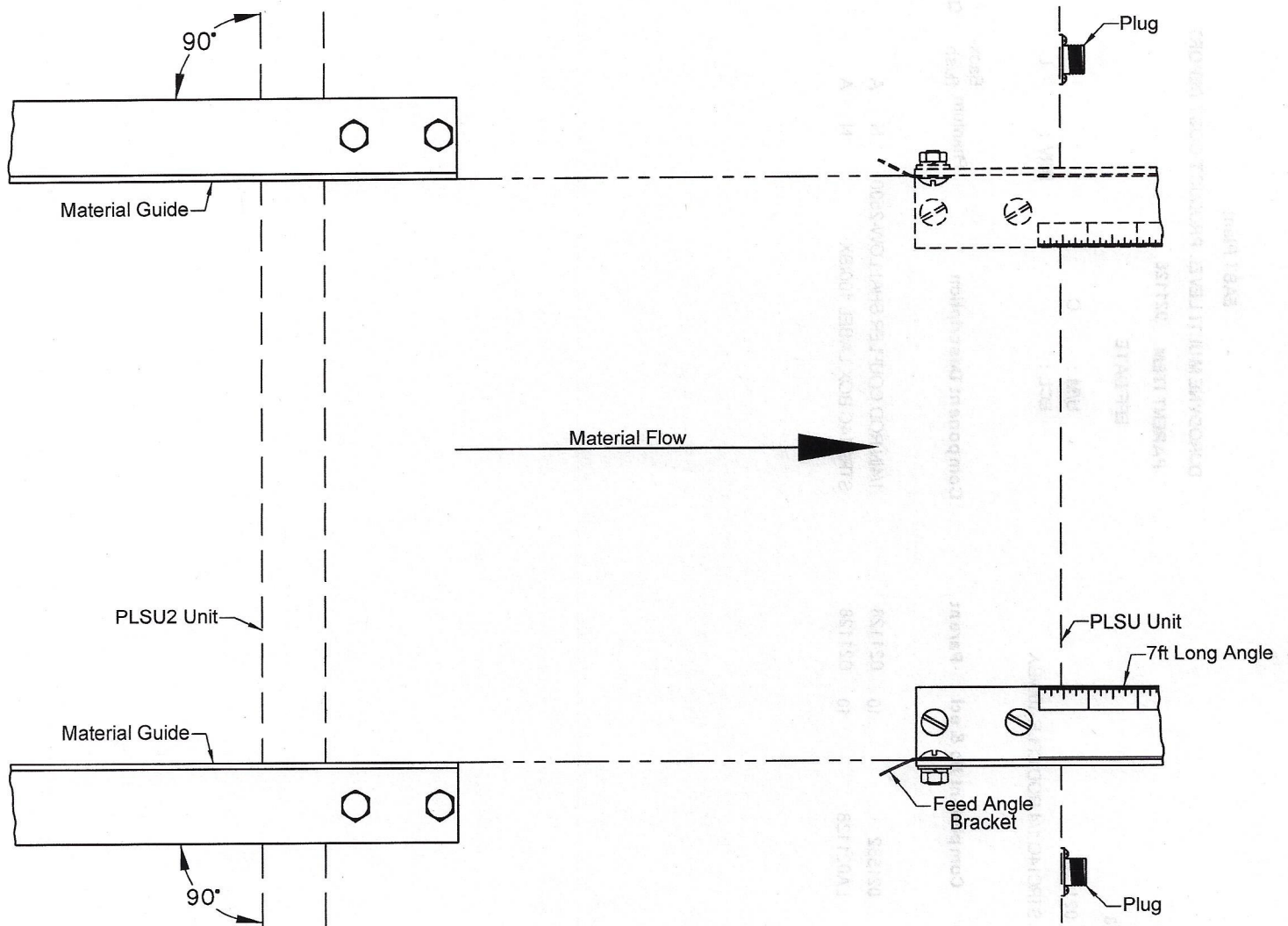

PLSU Material Guide Installation Instructions

(The PLSU2 Unit and its components are pre-set from the factory for Right Hand Mount operation)
To mount the **Material Guides** to the **PLSU2 Unit** properly, please note that all required hardware is pre-attached:

- 1)-Secure the **7ft Long Angle** before securing the **Material Guides**. Please refer to the instructions shown in the **Owner's Manual** or the separate Instruction sheet entitled "PLSU Control Module, Dog & Handle Installation Instructions" provided with the **PLSU2 Unit** for this installation.
 - 2)-Secure the **Material Guide** loosely using the **Hardware** already in place. Align the inner edge of the **Material Guide** with the inner edge of the **7ft Long Angle** as shown below. The **Material Guide** must be 90deg to the **PLSU2 Unit** as shown. Tighten the **Hardware** securely.
 - 3)-Secure the other **Material Guide** to the opposite side of the **PLSU2 Unit** loosely using the **Hardware** already in place. The **Material Guide** must be 90deg to the **PLSU2 Unit** as shown. Tighten the **Hardware** securely.
 - 4)-If changing the mounting of the **7ft Long Angle** from **Right Hand Mount** operation to **Left Hand Mount** operation, then follow the same method of attachment as above from the **Left** side of the machine.
- (THE CUTTING BLADES ARE VERY SHARP, PLEASE TAKE PROPER OPERATOR SAFETY PRECAUTIONS AS NEEDED)





PLSU Control Module, Dog & Handle Installation Instructions

Control Module and Sensor Mounting for Left or Right Hand Application:

(the Control Module, Sensor and Keeper are pre-set from the factory for Right Hand Mount operation)

- 1)-Secure the 7ft Long Angle to the PLSU Unit as per your Material Flow and the side of the machine that the operator will be working from. All required hardware is pre-attached. **NOTE:** the Feed Angle Bracket will need to be removed and placed on the other face of the 7ft Long Angle if you are changing the Controls from the Right Hand Mount. The Sensor and Keeper will also need to be reversed on the Track. Ensure the "open" end of the 7ft Long Angle height is parallel to the PLSU Unit for proper operation. A mounting apparatus will be needed if not attached to a table at the required height.
- 2)-Place the Control Module, Sensor and Keeper as shown in the appropriate view below and secure the Control Module Cord (not shown) to the Plug properly.

***AS NOTED BEFORE:** The PLSU Unit is pre-set for Right Hand Mount operation, this also applies to the Material Cradle Frame on the other side of the machine as well as the Hold Down Handle and Dog. If the 7ft Long Angle and its components are being changed to Left Hand Mount, then the Outer Ends of the Cradle Frame and the Dog also need to be changed.

Re-assemble the Dog as shown below. (Please refer to the page for the Material Cradle Assembly as required.)

(THE CUTTING BLADES ARE VERY SHARP, PLEASE TAKE PROPER OPERATOR SAFETY PRECAUTIONS AS NEEDED)

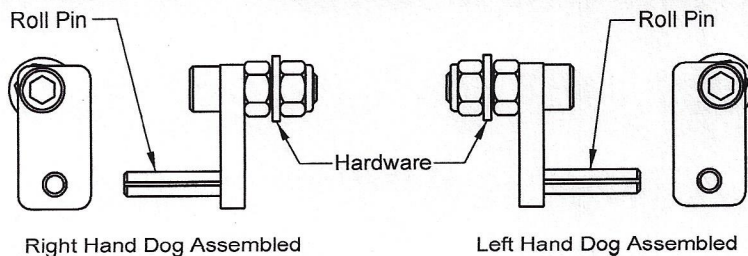
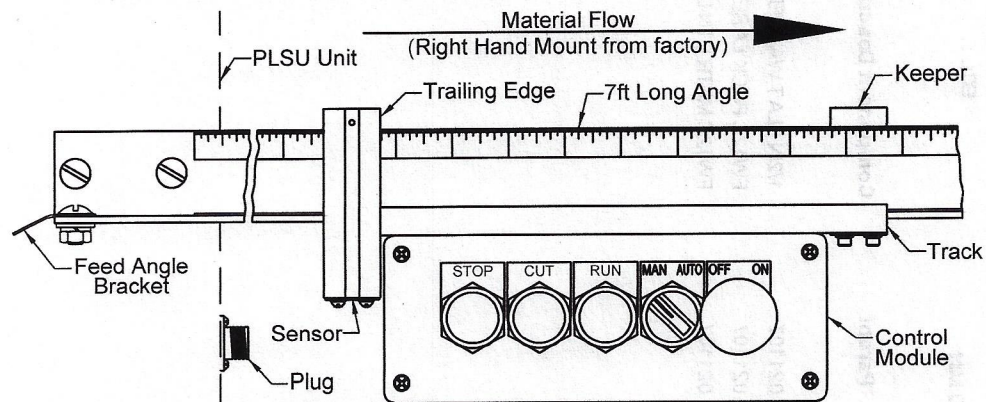
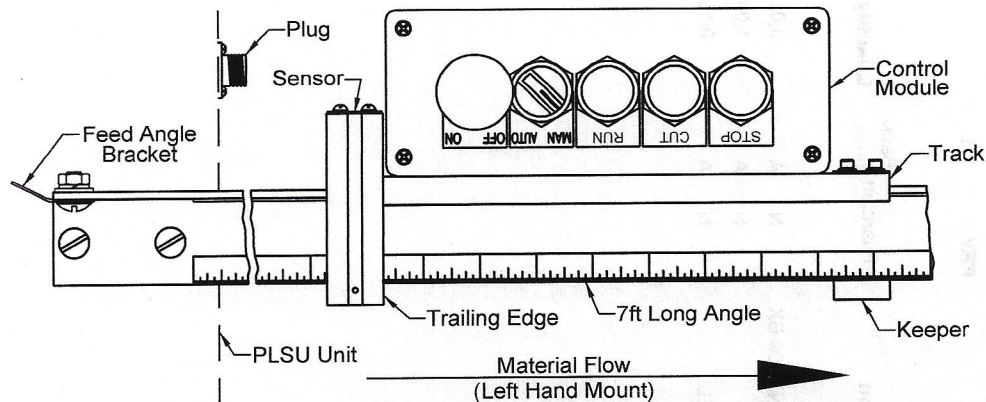

The Dog is also pre-set from the factory for Right Hand Mount operation: To change the Dog from Right Hand Assembly to Left Hand Assembly, reverse the Hardware orientation and push the Roll Pin through to the other face as shown at left.



PLSU2 Material Dispenser Assembly & Operation Instructions

IMPORTANT: This installation procedure requires at least two people. Take proper safety precautions.

(The Cutting Blades are very sharp, please take proper operator safety precautions as needed)

- 1)- PART-A (Liner Angle Left): Mounts to PLSU2 Frame Table. Use the two mounting holes that are the furthest to the outside left. Use the 1/4-20x1" bolts along with lock and flat washers. Just snug them for now.
- 2)- PART-B (Liner Angle Right): Mounts to PLSU2 Frame Table. Use the two mounting holes that are the furthest to the outside right. Use the 1/4-20x1" bolts along with lock and flat washers. Just snug them for now.
- 3)- PART-C (Liner Guide Rollers & Roller Bracket Assembly): Slide over PARTS-A and B and secure at the sixth hole in. Mount the Roller Brackets with the 3/8-16x1" bolts along with lock washers, flat washers and 3/8-16 nuts. Just snug them for now. If the Rollers do not spin freely at this point, PART-A and B may have to be slid inwards to loosen the tension on the PART-C Bracket.
- 4)- PART-D (Upright Legs with (2) Roller Support Channels mounted on it): Mount it to PART-A so that the Roller Support Channel faces away from the machine. Use Square U-Bolt, Square U-Bolt Mounting Plates and 3/8 lock washers and 3/8-16 nuts to mount channels. Mount to the outside of PART-A. Just snug them for now.
- 5)- PART-E (Rear Cross Brace): Mount to the bottom and top of PARTS-D. Angle should go under and over PARTS-D and face the outside. Use the 3/8-16x2.5" bolts along with flat washers, lock washers and 3/8-16 nuts. Just snug them for now.
- 6)- PART-F (Liner Angle Brace Left): Mount the slotted end to the angled end of PART-A in the outside hole. Use 3/8-16x1" bolt along with flat washers, lock washers and 3/8-16 nuts. Just snug them for now. Mount lower PART-F to lower PART-D. Use 3/8-16x3" bolt along with flat washers, lock washers and 3/8-16 nuts. Just snug them for now.
- 7)- PART-G (Liner Angle Brace Right): Mount the slotted end to the angled end of PART-B in the outside hole. Use 3/8-16x1" bolt along with flat washers, lock washers and 3/8-16 nuts. Just snug them for now. Mount lower PART-G to lower PART-D. Use 3/8-16x3" bolt along with flat washers, lock washers and 3/8-16 nuts. Just snug them for now.
- 8)- PART-H (Front Cross Brace): Mount between and under PARTS-A and B using the holes closest to the machine. Use 3/8-16 bolts along with flat washers, lock washers and 3/8-16 nuts. Just snug them for now.
- 9)- Level all horizontal parts. Straighten all vertical parts. Now tighten all nuts and bolts.
- 10)- PART-I (Liner Guide Bar Assembly-Fixed): Mount to the remaining holes on PARTS-A and B. Use 1/4-20x1" bolts along with flat washers and lock washers.
- 11)- PART-J (Hold Down Bar): Mount one to the top of parts-D. Use 3/8-16x3" bolts along with flat washers and nylon locking nut. Mount the other to the middle of PARTS-D. Just tighten down enough so bar is snug but can move freely up and down.
- 12)- PART-K (Insulation Support Bars): Mount on Roller Support Channels attached to PARTS-D.
- 13)- PART-L (Liner Feed Guide): May have to be relocated to other side of machine depending on insulation flow.

(FULL MACHINE ILLUSTRATION LOCATED ON PAGE-2)

PLSU2 Material Dispenser Assembly & Operation Instructions

IMPORTANT: This installation procedure requires at least two people. Take proper safety precautions.

