

RED RIVER MACHINERY  
1-800-729-0759  
www.redrivermachinery.com

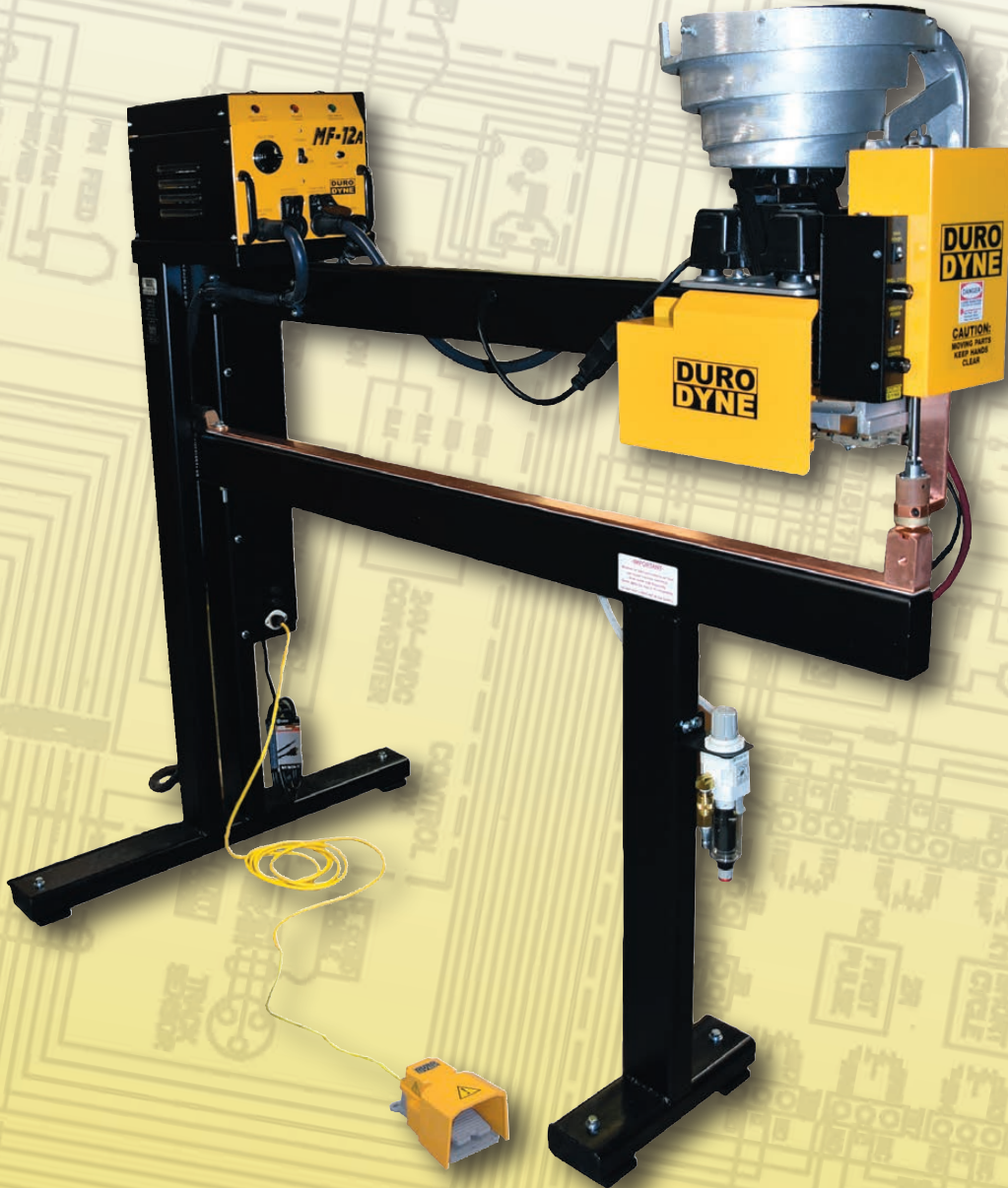

## AUTOMATIC BULK FEED 5FT. CONVERSION PLATFORM



# OWNER'S MANUAL

**DURO  
DYNE**

**MACHINERY**  
DIVISION



## ***INTRODUCTION***

Duro Dyne is proud to introduce the bulk feed concept of our FPP-5 Pinspotter. It will provide fast and efficient insulation fastening in your shop. The minimal material handling and utilization of welded clip pins will insure your shop of a cost efficient, quality product.

Trouble free service is the key to optimum production, and the FPP-5, with proven solid state components located for easy access, makes preventative maintenance a breeze.

This manual is designed to be a guide to keeping your FPP-5 operating at peak performance for years to come.

## ***IMPORTANT***

Always follow manufacturer's recommendations for proper safety and handling procedures for all materials used in conjunction with this machine as outlined in Manufacturer's Safety Data Sheet (MSDS) for each product.

## ***LIMITED WARRANTY***

Duro Dyne Machinery is manufactured by skilled mechanics, utilizing the latest production techniques. Each unit has been rigorously tested prior to packaging and shipment in order to ensure trouble-free operation.

Your Duro Dyne machine has a two year warranty against defects in material. Any component found to be defective will be repaired or replaced (at the manufacturer's discretion) at no cost if the faulty component is returned freight prepaid to the nearest Duro Dyne Service Department. The warranty does not apply to expendable parts or repairs or service due to improper maintenance or operation procedures.

Duro Dyne products have been engineered to maximize operator safety. Unauthorized modification of this product will void the warranty.

All warranty claims must be accompanied by a serial number, date of purchase and the name and address of the distributor it was purchased from.

## ***TABLE OF CONTENTS***

Installation Instructions	8
Introduction	2
Maintenance	8
Operation	8
Parts List	17
Parts Location	3-7
Servicing	13
Theory of Operation	12
Troubleshooting	13-17
Warranty	2
Wiring Diagrams	10-11

# ***PARTS LOCATION***

---

17049 Male Camlock

18024 FPP Rear

Ground Cable

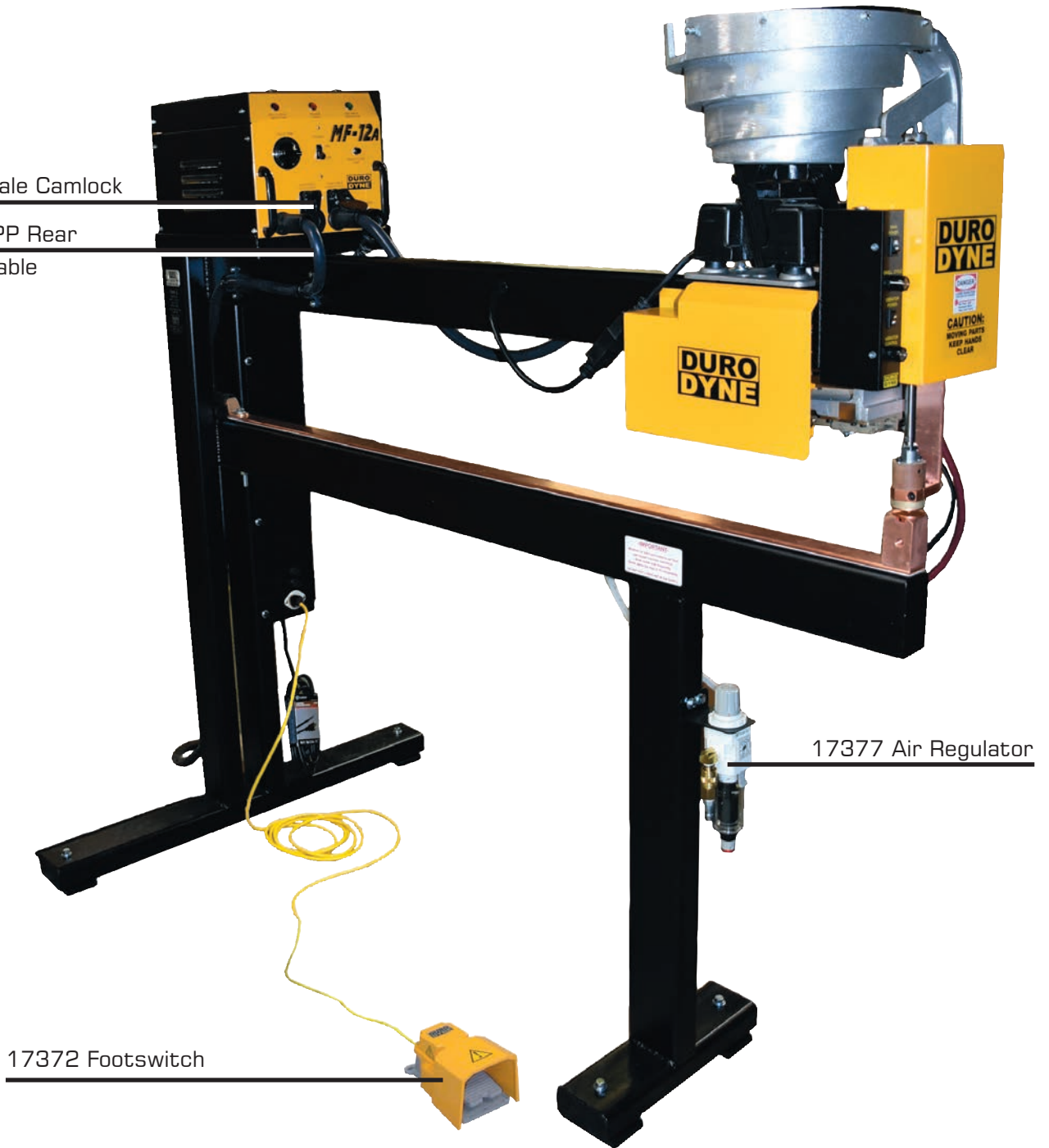

17377 Air Regulator

17372 Footswitch

17135 Lift Kit (Not shown)

---

## ***FRAME ASSEMBLY***

# ***PARTS LOCATION***

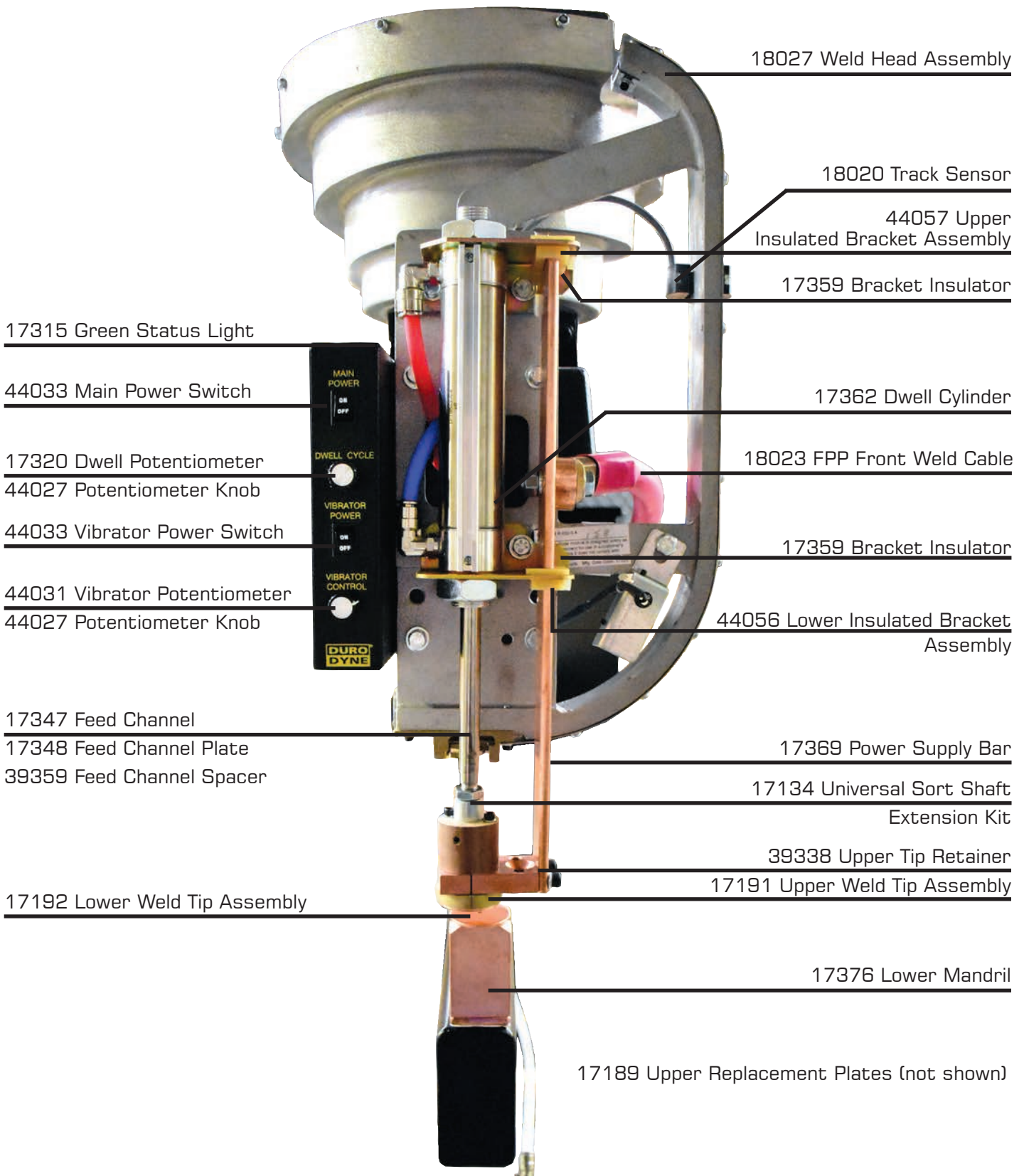

17315 Green Status Light

44033 Main Power Switch

17320 Dwell Potentiometer

44027 Potentiometer Knob

44033 Vibrator Power Switch

44031 Vibrator Potentiometer

44027 Potentiometer Knob

17347 Feed Channel

17348 Feed Channel Plate

39359 Feed Channel Spacer

17192 Lower Weld Tip Assembly

18027 Weld Head Assembly

18020 Track Sensor

44057 Upper Insulated Bracket Assembly

17359 Bracket Insulator

17362 Dwell Cylinder

18023 FPP Front Weld Cable

17359 Bracket Insulator

44056 Lower Insulated Bracket Assembly

17369 Power Supply Bar

17134 Universal Sort Shaft Extension Kit

39338 Upper Tip Retainer

17191 Upper Weld Tip Assembly

17376 Lower Mandril

17189 Upper Replacement Plates (not shown)

## ***DWELL & FEED ASSEMBLY (1)***

# ***PARTS LOCATION***

---

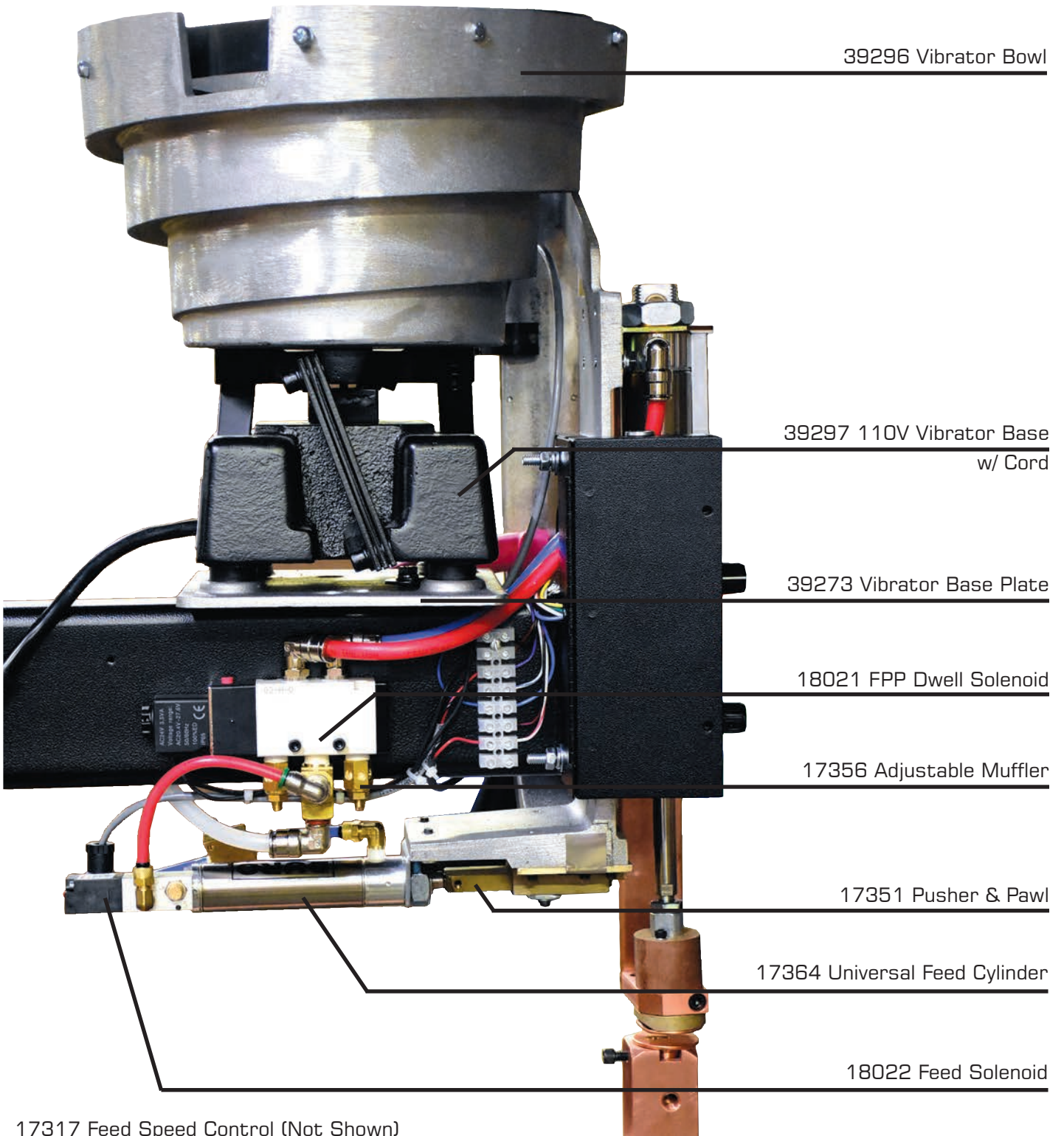

---

## ***DWELL & FEED ASSEMBLY (2)***

# ***PARTS LOCATION***

---

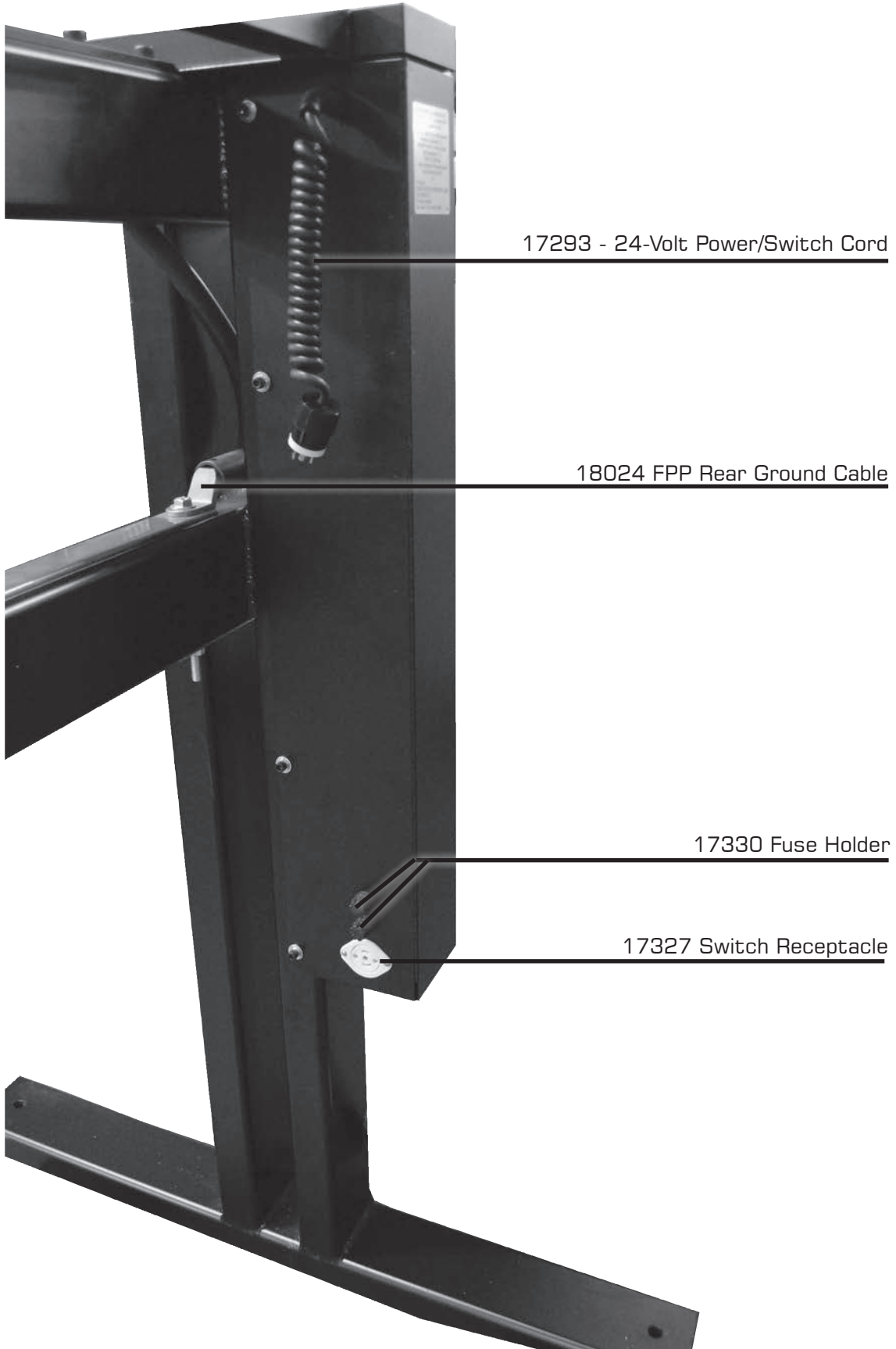

---

## ***COMPONENT CHASSIS ASSEMBLY - EXTERNAL***

# ***PARTS LOCATION***

---



44130 Laser Control PC Board

27353 22-12 Push-in Terminal Block  
27355 22-12 Push-in Term Grnd Block

17323 First Pulse Relay

17323 Short Cycle Relay

17323 Feed Relay

17319 Dwell Timer

17318 Feed Timer

39060 Delay Feed Timer

44097 Solid State Vibrator Relay

17148 Vibrator Speed Control

17320 Dwell Potentiometer

39068 Receiver Board

44047 Power Contactor

18029 24V Multi-Tap Transformer

---

## ***COMPONENT CHASSIS ASSEMBLY - INTERNAL***

# ***INSTALLATION INSTRUCTIONS***

---

- 1) Connect FPP-5 to a source 120 V 20 amp power
- 2) Connect MF12A to 208-230 60 amp single phase.
- 3) Attach foot switch to foot switch socket on rear of FPP-5
- 4) Connect air line to regulator. Adjust regulator pressure to 80-85 PSI.
- 5) Plug vibrator power plug into socket of FPP-5
- 6) Connect 24 volt initiate weld cord from FPP-5 to MF-12A Power/Switch Cord
- 7) Connect weld cables from FPP-5 to MF-12A in either the high or low plug (based on application).
- 8) Connect the ground cable into the MF12A.

# ***OPERATION - FPP5 INITIAL ADJUSTMENTS***

---

- 1) Turn main power switch to "ON" on FPP5.
- 2) Turn vibrator switch to "ON" on FPP5.
- 3) Add clip pins to hopper (vibrator bowl)
- 4) Adjust vibrator speed so that clip pins climb spiral track inside vibrator bowl without vibrating off.
- 5) When clip pins fill the track right up to the sensor, the vibrator automatically shuts off.
- 6) Turn MF-12A power switch on.

# ***STARTING OPERATION***

---

- 1) Never actuate unit without metal over ground bar or mandrel. For maximum weld quality metal should be in flat contact with mandrel adjacent table or roller on which sheet metal rests must either be exactly flush with or slightly below mandrel.
- 2) Weld Time on MF-12A and Dwell Cycle on FPP-5 settings control weld quality of the Pinspotter. Weld time is the length of the time the welding transformers are on. A fraction of a second is generally all the time needed for a quality weld. Unnecessary weld time not only wastes energy but can also burn up pins. (if pins glow red up to the washer, weld time is set too high) always set the weld timer to the minimum time required for a good weld. Dwell time is the length of time the welding tip remains in the down position. Always adjust the dwell timer to a setting slightly longer than the weld timer so that the upper weld tip will remain down until the weld cycle has ended and the weld has had time enough to cool.
- 3) Always "pre-test" a run with smaller pieces of the same gauge sheet metal thickness and liner density you intend to use in final production. Different densities and thicknesses of liner may require adjustments of the weld and dwell timer settings. For example: heavier gauge steel, thicker liner, higher density liner and/or longer clip pins may require longer weld and dwell time. To make sure, always pre-test and adjustment before you go into "finish production." But... only change weld and dwell timer settings when a change in materials results in poor weld performance or a poor quality weld.

# ***MAINTENANCE***

---

- 1) To prolong weld tip life and improve weld quality, it is imperative that weld tips always be kept clean. For best results, use a solvent to remove adhesive from tips; and a fine emory cloth to smooth tip surfaces.
- 2) When lower weld tip becomes worn in one area, loosen the locking cap screw and rotate the point of wear away from the point of contact of the tip. If this cannot be done because the lower weld tip is too badly pitted. Additional lower weld plates can be ordered from your local distributor.
- 3) Depending on usage and maintenance, upper welding tip plate will have to be periodically replaced. Replacement weld tip plates can be ordered from your local distributor. To replace the upper weld tip, loosen the locking cap screw and remove the weld tip. Remove plate by loosening three (3) brass screws. Throw away screws and attach new plate to tip using three brass screws supplied. Be sure to match angled section of the plate with undercut running parallel to frame, then lock tip in place. Cycle machine to check feeding
- 4) If feeding is erratic, re-adjust upper weld tip height by loosening lock nut and then turning weld cylinder shaft clockwise to raise tip; counterclockwise to lower tip. Lock tip in place with locking nut.



# FPP5 DRAWING

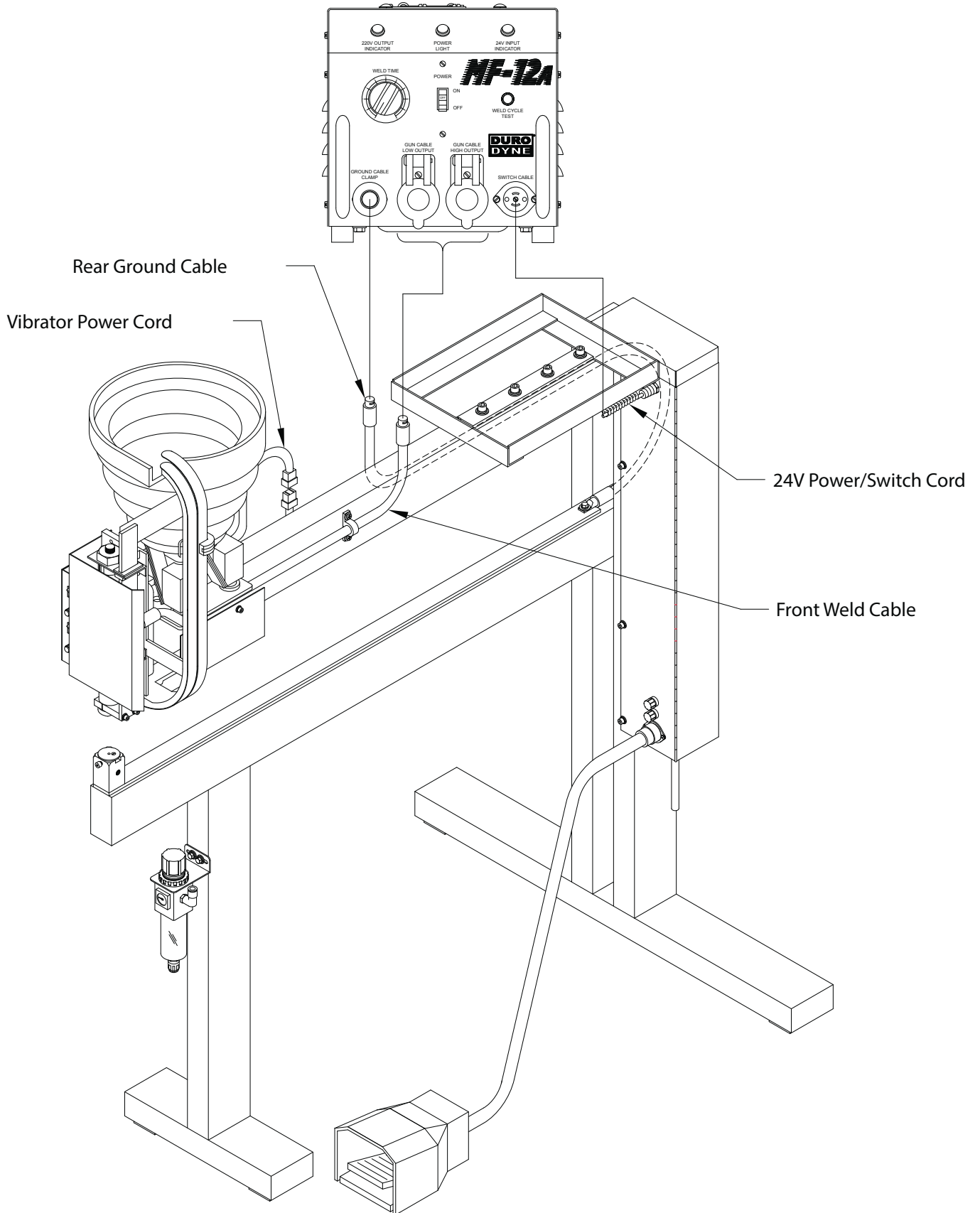

# WIRING DIAGRAM

1-14-21(8386-01-17)(CR-1282/REV-C)/GO

## FPP5 WIRING DIAGRAM

[B.C.] = BUTT CONNECTOR

[□] = DUAL MALE/FEMALE ADAPTOR

[---] = 1/4" SHRINK TUBING-BLACK

ALL WIRES=18GA  
(EXCEPT AS NOTED)

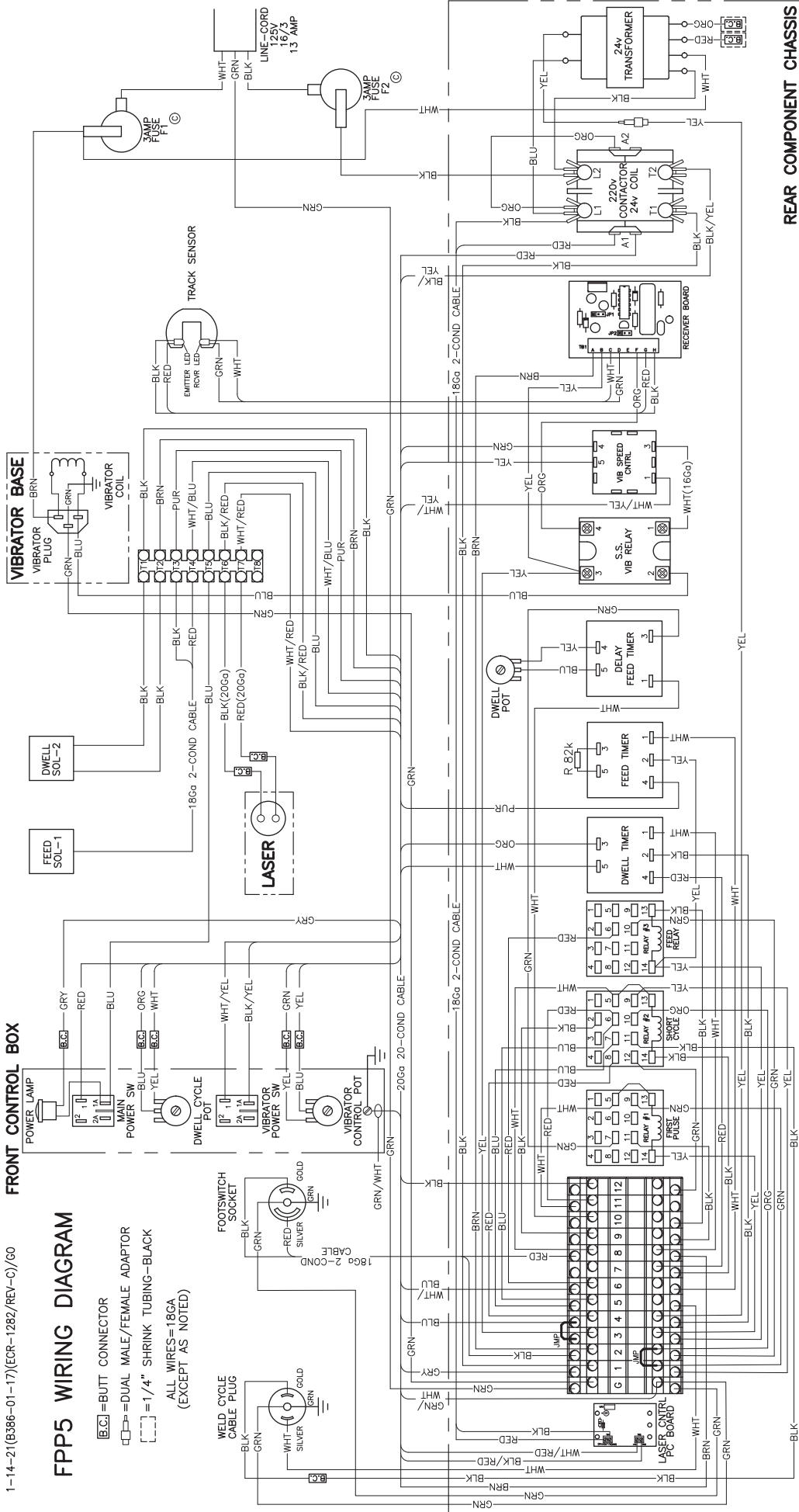

REAR COMPONENT CHASSIS

FPP5

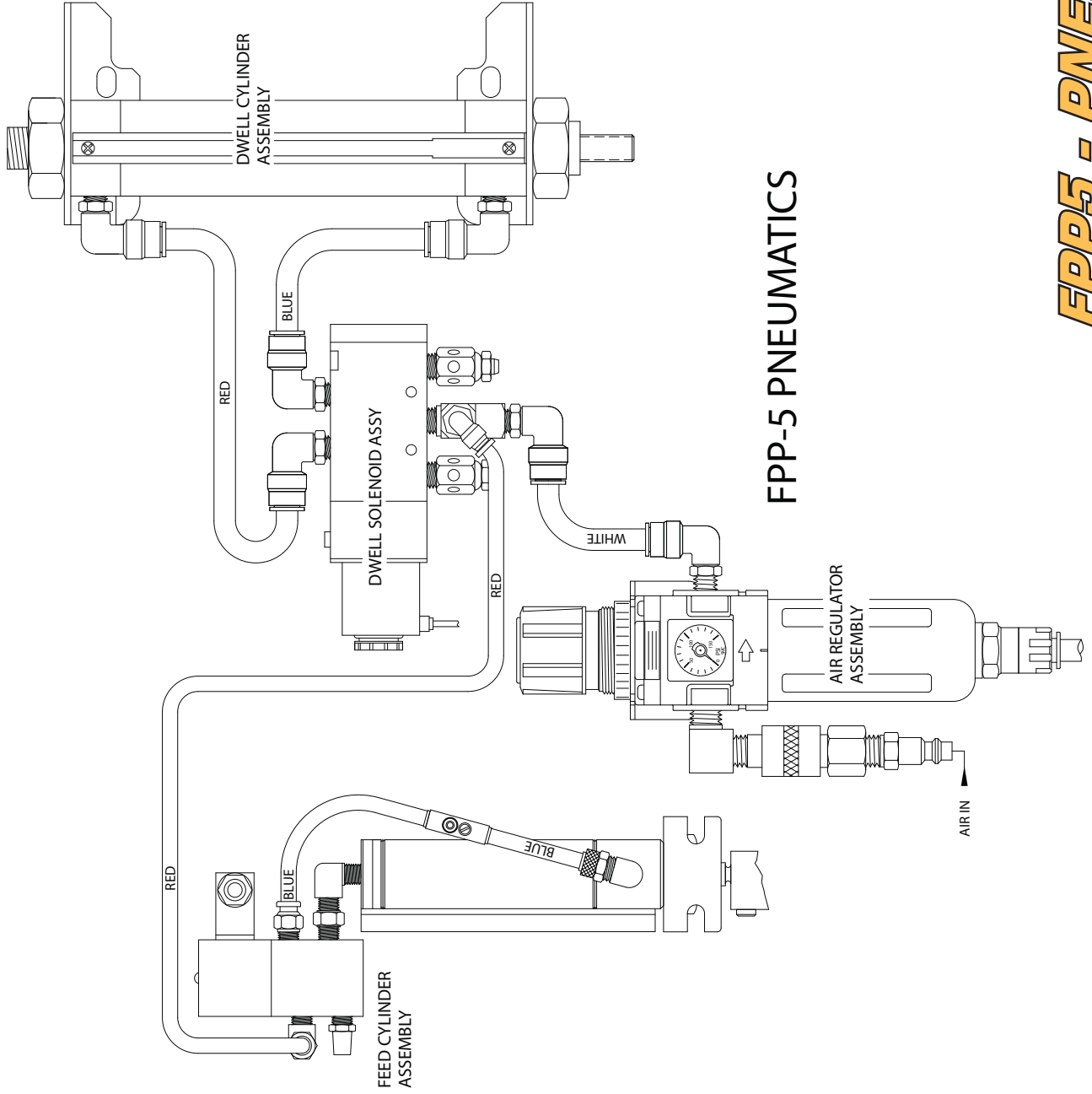

**FPP-5 PNEUMATICS**

# ***FPP5 BASIC PINSPOTTER FUNCTION***

---

The **FPP-5** is a 110 volt insulation fastening machine designed for use in the HVAC industry. A welding power source is not included with the **FPP-5**. The **FPP-5** is fully assembled for pneumatic and electronic control including;

1. Weld pin feeder and bowl for weld pins up to 2 inches long.
2. Weld pin feed track.
3. Weld pin feed track sensor.
4. Electronic component chassis assembly.
5. Main power, Vibrator power and Dwell cycle control box assembly.
6. Upper weld tip assembly.
7. Lower weld tip assembly.
8. Foot pedal weld activation.
9. Air regulator assembly.
10. Compact 5 foot throat welded frame.

The **FPP-5** is to be used in conjunction with the Duro Dyne portable MF12A (DD p/n 27110) Portable hand held welding gun pin spotter as a welding power source (208-230 volt 60HZ) single phase 60 amp service. The **FPP-5** can be purchased with the MF12A or without for Duro Dyne customers who may have previously purchased a Duro Dyne portable MF12A pin spotter.

The **FPP-5** receives a welding power source from the MF12A after the MF12A is placed on to the **FPP-5** mounting frame weldment and the MF12A ( after removing the hand gun and ground clamp cam locks) is connected to a 208-230 volt 60HZ, single phase 60 amp service. The MF12A welding source will transfer power to the **FPP-5** by means of connecting the **FPP-5** Front and Rear Weld Cable Cam locks and the 24 volt Power/Switch cable to the MF12A.

## **Description of how pin spotters currently perform in the HVAC Industry**

Pin spotting insulation fastening machines currently perform in the HVAC industry as follows:

Typically pin spotting insulation fastening machines are manufactured with a transformer or a series of transformers designed to supply the pin spotting machine with a welding power source operating within the following theory.

Pinspotter Machine theory of operation

## #1 MACHINE DOES NOT OPERATE - NO POWER INDICATOR

POSSIBLE PROBLEM	ACTION
(A) Incoming power supply.	(A) Check the incoming power (120vac) at terminals L2 on the Power Contactor and Fuse #2. If 120vac is not present check fuses and power supply. If 120vac is present go to step B.
(B) Power Contactor.	(B) Check the voltage (24vac) at the coil of the contactor in the component module. If the voltage is present, check voltage (24vac) at terminals 1 and 4 on the terminal strip. If voltage at the contactor coil is present and terminals 1 and 4 have no voltage replace contactor, if voltage at contactor coil is not present proceed to step C.
(C) Main Power Switch.	(C) Check the Main Power Switch terminals 1a and 2a on the Control Console. Terminals 1a and 2a should have 24vac when the switch is "OFF", and 0vac when the switch is "ON". If the voltage stays 24vac replace the switch. If the voltage stays 0vac proceed to step D. (*NOTE* 1a and 2a can be jumped, also the Main Power Switch is a DPST switch that is only using one set of contacts, if the switch is not working the unused contacts can be used to see if it works*)
(D) 24VAC Transformer.	(D) In the Component Module, check the transformer primary input voltage (120vac) at terminal L2 on the Power Contactor and Fuse 2. Check the secondary voltage (24VAC) at the coil of the Contactor. If the voltage at the coil is not present and step (C) is correct replace the Transformer.

## #2 MACHINE DOES NOT OPERATE - POWER INDICATOR ON

POSSIBLE PROBLEM	ACTION
(A) Footswitch.	(A) Check the voltage (24VAC) at terminals 4 and 8 in the Component Module while depressing the Footswitch. This voltage reading should go from 0vac to 24vac. If the voltage reading is not correct replace or repair the Footswitch.
(B) Dwell Timer.	(B) Turn the Dwell time to the highest setting and check the voltage (24vac) at terminals 8 and 9 in the Component Module. This voltage should come on then go off (0vac-24vac-0vac) every time the Footswitch is depressed. If this voltage reading is not correct replace the Dwell Timer.
(C) Short Cycle Relay.	(C) Turn the Dwell to the highest setting and check the voltage (24vac) at terminals 7 and 8 in the Component Module. This voltage reading should go from 0 to 24vac and then back to 0 every time the Footswitch is depressed. If this voltage reading is not correct recheck the symptom. Now do this same procedure at terminal 8 and 12 in the Component Module, if the voltage reading is incorrect replace the Short Cycle Relay.
(D) Air Pressure, Adjustable Exhaust Muffler, and Dwell Cylinder	(D) Check Air Regulator for proper setting (80psi). Now press the test button located on the Dwell Solenoid Body. If the Dwell Cylinder does not operate check the Adjustable Exhaust Mufflers on the Dwell Solenoid for proper adjustment. If the mufflers are closed or restricted it will not allow the Dwell Cylinder to operate. Also check the cylinder by turning the air off and then move the shaft up and down. The shaft should move freely. If the mufflers (these mufflers control the speed of the up and down motion on the cylinder) are properly adjusted and have no restrictions and the Dwell Cylinder operates when the test button is pressed proceed to step (B).
(E) Dwell Solenoid.	(E) Turn the Dwell time to the highest setting and check the voltage (24vac) at terminals 8 and 12 in the Component Module. The voltage reading should go from 0 to 24vac and back to 0 every time the Footswitch is depressed. If this voltage reading is correct replace the Dwell Solenoid. (*NOTE* before replacing the Dwell Solenoid check the wires going into the plug of the Dwell Solenoid*)

## #3 PIN FEED PROBLEMS

POSSIBLE PROBLEM	ACTION
(A) First Pulse Relay. (Coil)	(A) The First Pulse Relay should engage the first time the machine cycles and should stay engaged until the power is turned off. To check the first Pulse Relay jump terminals #1 to #10 in the trolley. With this jumper in place and the power on check the voltage (24VAC approx) at terminals #3 and #10. If voltage is present and the Relay is engaged (the Indicator on the Relay is on) proceed to step (B). If the voltage is present and the Relay is not engaged (No indicator on the Relay is off) replace the First Pulse Relay.
(B) First Pulse Relay. (Contacts)	(B) If the Relay is engaged (the Indicator on the Relay is on) check the voltage (24VAC approx) at the terminals #3 and #11 in the Component Module. If the voltage is not present replace the First Pulse Relay. If the voltage is present proceed to the next step.
(C) Feed Timer	(C) The Feed Timer activates the Feed Solenoid. In the Component Module check the voltage (24VAC approx) at terminal #1 and #4 on the Feed Timer. The voltage at terminal #1 and #4 should go from 0 to 24VAC and back to 0 on every cycle. If this voltage reading is incorrect replace the Feed Timer. If the voltage reading is correct proceed to the next section. (This voltage is only present for 150ms. Some voltmeters may not react fast enough to see this voltage)
(D) Feed Solenoid, Feed Cylinder, and Pusher With Pawl.	(D) The Feed Solenoid controls the Feed Cylinder. To test the Feed Solenoid check the voltage (24VAC approx) at terminals #1 and #4 on the Feed Timer in the Component Module. Terminals #1 and #4 should go to 24VAC and back to 0 on every cycle. If correct turn power and air off. Now try to move the Pusher With Pawl in and out. The Pusher With Pawl should move easily. If so, replace the Feed Solenoid. If not, check for jammed weld pins in the Feed Channel or for a damaged Feed Cylinder. Also check the Feed Speed Control, (located on the air line going to the Feed Cylinder) for proper adjustment.

## **#4 FEED CYLINDER DOES NOT RETRACT**

<b>POSSIBLE PROBLEM</b>	<b>ACTION</b>
(A) Feed Timer: <b>Feed Cylinder does not retract.</b>	(A) Remove the push-on connector from terminal #4 of the Feed Timer. If the Feed Cylinder retracts replace the Feed Timer. However, check 82K resistor on terminal 3 & 5 of the timer first to see if broken or loose. If resistor broke, replace resistor.
(B) Feed Cylinder or Pusher With Pawl.	(B) Turn the power off and inspect the Feed Cylinder for air leaks. If there are no air leaks turn the air off and slide the Pusher With Pawl in and out. The Pusher With Pawl should go in and out with just a slight restriction.
(C) Feed Solenoid.	(C) To check the Feed Solenoid turn the power off. If the Feed Cylinder does not retract and step (A) above is correct replace Feed Solenoid.

## **#5 FEED COLLIDES WITH DWELL**

<b>POSSIBLE PROBLEM</b>	<b>ACTION</b>
(A) Feed Delay Pot and Dwell Cylinder Adjustable Muffler	(A) The feed cycle is a timed circuit. The Feed Delay Timer is set to hold the feed signal until the Dwell Cylinder is fully retracted. If the Feed Delay Pot or the Adjustable Muffler for the Dwell Cylinder up-stroke are adjusted, this can cause the Feed Cylinder and Dwell Cylinder to collide.

## **#6 SLUGGISH MOVEMENT OF THE FEED**

<b>POSSIBLE PROBLEM</b>	<b>ACTION</b>
(A) Feed Speed Control	(A) Readjust the Feed Speed Control located on the air line going to the Feed Cylinder.
(B) Air Lines	(B) Check Air Lines for leaks or water. If there is water in the air lines, disconnect and blow out the Air Lines. Remove and clean out the adjustable exhaust mufflers. Reconnect the Air Lines and the Adjustable Exhaust Mufflers.
(C) Feed Cylinder	(C) Turn the power and air off. Check the Feed Cylinder and the Pusher with Pawl for binding. Move the Pusher with Pawl in and out. The pusher with pawl should move in and out with a slight resistance.
(D) Feed Solenoid	(D) If the above procedures check out and the Feed still has sluggish movement the problem may be the Feed Solenoid. Remove the Air Line from air inlet of the solenoid and spray a light oil into the solenoid. Reconnect the Air Line and cycle the machine. If the Feed still has sluggish movement replace the Feed Solenoid.

## **#7 FEED DOES NOT PLACE WELD PIN ON UPPER WELD TIP**

<b>POSSIBLE PROBLEM</b>	<b>ACTION</b>
(A) Feed Speed Control.	(A) If the Feed Speed Control is open too much it may throw pins past the Upper Weld Tip. Adjust Feed Speed Control so that it places the pin on the Upper Weld Tip.
(B) Upper Weld Tip	(B) Check the Upper Weld Tip for magnetism. Place a weld pin under the Upper Weld Tip. If the tip does not retain the pin or the magnets feel weak replace the Upper Weld Tip.
(C) Pusher with Pawl	(C) The pawl (hinged part) on the pusher may be damaged or missing. If so replace the Pusher With Pawl.
(D) Upper Tip Height	(D) Adjust weld tip by loosening the jam nut on shaft of Dwell Cylinder. Turn shaft to raise or lower weld tip. Weld should be at the same height as the ceiling of the feed channel.

## **#8 DWELL CYLINDER DOES NOT RETRACT**

<b>POSSIBLE PROBLEM</b>	<b>ACTION</b>
(A) Dwell Timer	(A) Remove the push-on connector from terminal #4 of the Dwell Timer. If the Dwell Cylinder retracts replace the Dwell Timer.
(B) Dwell Solenoid	(B) Turn the power off. (If the Dwell Cylinder shaft retracts, recheck the symptom). Now try and lift the Dwell Cylinder shaft up. If the cylinder shaft cannot be lifted replace the Dwell Solenoid.
(C) Dwell Cylinder	(C) If the Dwell Cylinder shaft can be lifted easily check the Dwell Cylinder and the air lines for air leaks. Turn the air off and then move the cylinder shaft up and down. If the cylinder shaft moves up and down without any air resistance the seals in the cylinder are most likely worn. Replace the Dwell Cylinder. If a slight air resistance is present on the up and down motion check the Quick Exhaust Valve.

## **#9 DWELL CYLINDER SLUGGISH MOVEMENT**

<b>POSSIBLE PROBLEM</b>	<b>ACTION</b>
(A) Quick Exhaust Valve	(A) The quick exhaust valve is a pneumatic check valve. To check the Quick Exhaust Valve, disassemble the valve and inspect the conical shaped diaphragm for any tears. If any damage is noted, replace the Quick Exhaust Valve or repair it with a repair kit (part # 17078).
(B) Air Regulator	(B) Adjust the Air Regulator (80 psi).
(C) Air lines and adjustable Exhaust Mufflers	(C) Check Air Lines for leaks or water. If there is water in the Air Lines, disconnect and blow out the Air Lines. Remove and clean out the Adjustable Exhaust Mufflers. Reconnect the Air Lines and the Adjustable Exhaust Mufflers.
(D) Dwell Cylinder	(D) Turn the power and air off. Check the Dwell Cylinder shaft for binding by moving the shaft in and out of the cylinder. A slight air resistance should be present when the shaft is being moved in and out of the cylinder.
(E) Dwell Solenoid	(E) If the above procedures check out and the dwell cylinder still has sluggish movement, the problem may be the Dwell Solenoid. Remove the Air Line from air inlet of the solenoid and spray a light oil into the solenoid. Reconnect the air line and cycle the machine. If the Dwell Cylinder still has sluggish movement replace the Dwell Solenoid.

## **#10 PINS DO NOT WELD**

<b>POSSIBLE PROBLEM</b>	<b>ACTION</b>
(A) Short Cycle Relay.	(A) The Short Cycle Relay controls the circuit that signals the MF12 to turn it's weld on. To test the Short Cycle Relay place meter leads on the outside prongs of the 24 volt Power/Switch Cable Plug and test for continuity as the FPP5 is cycled. If continuity is NOT present, check for continuity at terminals 2 and 5 in the Component Module: If continuity is present: check Weld Cycle Plug for damage If continuity is not present: replace Short Cycle Relay *If continuity is present at 24 volt Power/Switch Cable Plug, refer to MF12/12A manual.

## **#11 POOR WELD QUALITY**

<b>POSSIBLE PROBLEM</b>	<b>ACTION</b>
(A) Weld Cable.	(A) Any secondary connection from the MF-12A to the weld tips can contribute to a poor quality weld. All the connections should be <b>clean, bright and tight</b> . The Weld Cable can break down from use. Always inspect the Weld Cable, all secondary connections and weld tips for they are the most common causes for a poor weld quality.
(B) Upper and Lower Welding Tips.	(B) Clean and Retighten
(C) Upper Tip Retainer.	(C) Clean and Retighten
(D) Female Camlock	(D) Clean and Retighten
(E) Flush Mount Camlock	(E) Clean and Retighten
(F) Power Supply Bar	(F) Clean and Retighten

## **#12 VIBRATOR DOES NOT VIBRATE AT ALL**

<b>POSSIBLE PROBLEM</b>	<b>ACTION</b>
(A) Fuses	(A) Check the Fuses (Located on the rear of the Control Module.(120VAC)
(B) Vibrator Power Switch.	(B) Check the Vibrator Power Switch in the Control Console. (120VAC approx.)
(C) Vibrator Sensor and Receiver Board	(C) The Track Sensor controls the Receiver Board which controls the Vibrator Control Relay. Check the Track Sensor for the red LED. If the LED is not on, check the terminals G and H on the Receiver Board in the Control Module for the 12 V dc. If the voltage is present, replace the Track Sensor. If the voltage is not present at G and H, check for 24 V ac at terminals A and B. If the voltage is present at A and B, replace Receiver Board. If the LED is on, jump C and D on the Receiver Board. This should make the vibrator run. If the vibrator runs, check the line of sight through Track Casting. If the line of sight is good, replace the Track Sensor. If the vibrator still does not run, jump A and F on the Receiver Board. If the vibrator now runs, replace Receiver Board. If the vibrator still does not run, proceed to next step.
(D) Vibrator Relay	The Vibrator Relay is located in component module. To check the vibrator relay look for 24VAC at terminal #3 (yellow wire) and terminal #4 (orange wire) on the vibrator relay. If voltage is not present return to above steps. If voltage is present now test voltage (120VAC) at terminal #1 (white wire) on vibrator relay to terminal #T2 on contactor. If voltage is not present go to next step (E). If voltage is present now check voltage terminal #2 (blue wire) to terminal #T2 on contactor. If voltage is not present replace vibrator relay. If voltage is present check vibrator plug and cord.
(E) Vibrator Speed Control.	(E) In the Component Module, check for voltage (120 VAC approx.) at terminals #1 and #3 on the Vibrator Speed Control. If there is 120 VAC at terminals #1 and #3 replace the Vibrator Speed Control.
(F) Vibrator Coil.	(F) Measure the resistance at the plug (two outside pins) of the Vibrator Base. The resistance reading should be approximately 4.5 ohms. If this reading is not correct replace the Vibrator Coil.

## ***#13 VIBRATOR VIBRATES BUT NOT ENOUGH TO MOVE WELD PINS***

<b>POSSIBLE PROBLEM</b>	<b>ACTION</b>
(A) Vibrator Speed Control.	(A) To test the Vibrator Speed Control place your hand on the Vibrator Bowl and watch the Vibrator Sensor Indicator. Now adjust the Vibrator Speed Control from slow to fast and back. If you feel no change in the intensity on the bowl or see any change in the intensity on the Vibrator Sensor Indicator, replace the Vibrator Speed Control located in the Control Console. If a change in the intensity is present, contact Duro Dyne Technical Support.

### ***NOTES:***

1. Check that the Air Regulator is set for 80 psi. Mounted on the top of the Trolley are two Adjustable Exhaust Mufflers. The front one adjust the speed of the Dwell Cylinder moving down and the rear one adjust the speed up. These mufflers can become restricted or loose. If machine is sluggish or starts slamming down, adjust these mufflers accordingly.
2. Mounted on the Feed Cylinder is a Feed Speed Control. The Feed Speed Control adjusts how fast the Pusher with Pawl moves in and out. If adjusted too fast the pins may be tossed past the tip, if adjusted too slow the pins will not be placed on the tip.



## ***PARTS LIST***

17049	Male Camlock	18023	Front Weld Cable
17134	Universal Short Shaft Extension Kit	18024	Rear Ground Cable
17135	Lift Kit	18025	Feed Cylinder Guard
17148	Vibrator Speed Control	18026	Dwell Cylinder Guard
17189	Upper Replacement Plates - Unplated	18027	Weld Head Assembly
17191	Upper Weld Tip - Unplated	18028	3 Amp Fuse
17192	Lower Weld Tip - Unplated	18029	24V Multi-Tap Transf
17269	Feed Cylinder Bracket	18031	Upper Replacement Plates - Plated
17293	24V Power/Switch Cord	18032	Lower Replacement Plates - Plated
17317	Feed Speed Control	18033	Upper Weld Tip - Plated
17318	Feed Timer	18034	Lower Weld Tip - Plated
17319	Dwell Timer	27315	24V Green Light
17320	Dwell Potentiometer	27353	22-12 Push-in Terminal Block
17222	Terminal Strip	27355	22-12 Push-in Term Grnd Block
17323	First Pulse Relay	39068	Receiving Board
17323	Short Cycle Relay	39273	Vibrator Base Plate
17327	Switch Receptacle	39296	Vibrator Bowl
17330	Fuse Holder	39297	110V Vibrator Base w/cord
17347	Feed Channel	39338	Upper Tip Retainer
17348	Feed Channel Plate	39359	Feed Channel Spacer
17351	Pusher & Pawl	44027	Weld/Vibrator Potentiometer Knob
17356	Adjustable Muffler	44031	Vibrator Pot
17359	Bracket Insulator	44033	Main Power Switch
17362	Dwell Cylinder	44033	Vibrator Power Switch
17364	Universal Feed Cylinder	44047	Power Contactor
17369	Power Supply Bar	44056	Lower Insulated Bracket
17372	Foot Switch	44057	Upper Insulated Bracket
17376	Lower Mandrel	44097	Vibrator Control Relay
17377	Air Regulator	44129	Class-1 Laser
18020	Track Sensor	44130	Laser/Control PC Board
18021	Dwell Solenoid	44131	Laser/Control PC Board Kit
18022	Feed Solenoid		