

TIN KNOCKER

TK 1524 SPOTWELDER

INSTRUCTIONS & PARTS DIAGRAM



RED RIVER MACHINERY
1-800-729-0759
www.redrivermachinery.com

**TIN KNOCKER
SAFETY RULES
TK 1524 SPOTWELDER**

1. Never use a machine or tool for anything other than its intended purpose. Use the proper tool and equipment for the task.
2. Do not operate the machine in excess of its rated capacity (2 pieces of 16 gauge mild steel at 24 inches).
3. **WARNING:**
Electrical Danger---Misuse or improper installation of machinery connected to a source of electricity may result in accidental shock that could cause injury or death. Installation must conform to National Electric Code (Article 250-Grounding, etc.)

A trained and qualified electrician must make electrical connections. Electrical characteristics shown on control panel must match the power source; and all electrically powered equipment must be grounded.

WARRANTY

All new machines are sold with a one-year limited warranty, on factory defective parts. The warranty is limited to the original user. TAAG Machinery Co. at its option, will repair, replace or refund the purchase price of any part, tool or machine that fails during the warranty period. TAAG Machinery Co. will pay normal shipping charges for replacement parts. After 90 days from date of purchase, all express or overnight delivery charges are the responsibility of the customer. Purchaser must deliver to TAAG Machinery Co., at the address below, any written claim, with proof of original purchase. Replacement parts will be invoiced to purchaser and credit issued when the failed part is delivered to TAAG Machinery Co. Removal, reinstallation or replacement parts shall be at purchasers' / user's expense. Failure due to improper use of the machine voids the warranty.

NOTE: 1. This machine has been tested and adjusted prior to shipment, but can and often does require readjustment due to vibration and bouncing during transport. Following the procedures described within can easily do readjustment. These are procedures with which you, as a user, should be familiar, as you will use them repeatedly over the life use of the machine. If you have difficulty in performing these procedures, we are here to support you.

TK 1524 SPOT WELDER,

SPECIFICATIONS:

15 KVA @ 24 inches 2 pieces of 16-gauge mild steel (.060)

230 volt / 1 phase / 60 hertz

100 Amp Draw (spot welder should be located as near electrical panel as possible. A trained and qualified electrician must make electrical connections.)

6 Points of heat control

1 ¾ inch horn Diameter

11 inch Max. Spacing Between Horns.

Shipping weight 675 lbs. approximate.

Water recycle system with a rust inhibitor (car anti freeze) should be used for tip cooling.

Tip size #2 Morse taper (CMW Inc. General Office 70 South Gray Street P.O. Box 2266 Indianapolis, IN 46206 Phone 317-634-8884).

RECEIVING THE MACHINE

Inspect before signing Bill of Lading. Upon receipt closely examine the machine for damage during shipment. Any loss or damage should be noted in detail on the delivery receipt and reported to your distributor immediately.

INSTALLING THE MACHINE

Bolt and Level To floor:

Water supply should be such that a minimum of 30-PSI inlet pressure is supplied. As a rule of thumb the return line should be one size larger than inlet to minimize backpressure. Ideal water temperature is 68 degrees Fahrenheit to 70 degrees Fahrenheit. Make sure hose connections are tight.

Electric – Primary power should be checked to insure it is the same as required at welder. Resistance welders typically draw current in excess of nameplate rating, which requires that all supply lines be such as to prevent voltage drop. Insure all connections are tight. TK spot welders are supplied in 230 volt, single phase only.

ADJUSTMENT PROCEDURE

WARNING: BEFORE ANY ADJUSTMENT'S ARE MADE IN THE CABINET TURN OF MAIN POWER SUPPLY.

Tips are set at a standard of 3 inch between them any variations of this standard will cause an adjustment to one or more of the following areas. If the (32) foot treadle extension contacts the floor before tips meet or welding begins. Loosen 2 nuts to the top of (26) Rod extension to bring the foot treadle up higher. Then relock 2 nut at the top on rod extension. This may require (29) comp. spring to be tightened by moving (34) compression spring retainer up. These adjustments may cause the (40) actuating dog to need to be moved up in order for (48) copper contact plat to contact the (49) contractors. To shorten foot pedal stroke and start welding process sooner move contacts closer to contact plate.

OPERATING THE TK 1524 Spot welder

Spot welding two or more thickness of sheet metal is accomplished by applying pressure upon the surfaces of the sheets through two relatively small welding tips, so that the sheets are forced tightly together at this area, and then passing an electric current through the tips and the sheets until the latter reach the melting or welding temperature. The pressure is maintained after the current is cut off until the weld has cooled and solidified.

The spot welding machine is designed to perform this welding cycle automatically. The proper spot welding machine settings, that is, size of the end of welding tips, the applied pressure, magnitude and time of duration of welding current, etc., to be used for a certain job, depend on many factors such as material, surface condition, size and strength of spot welds desired, etc.

1. **Material:** The material to be welded should be free from dirt, paint, and other foreign matter. Scale, rust, oxide, and other products of corrosion prevent the obtaining of best results, although welds can be made under these conditions at the expense of production, appearance and uniformity. A light film of clean oil or grease is not harmful. Coated and plated steels, such as Terne Plate, TinPlate, Galvanized Steel, etc., usually can be readily spot welded. More welding current and about 25% greater pressure is required than for the same gauge of uncoated steel.
2. **Part Fit Up:** Sheet metals should fit closely along the surfaces to be spot welded so that extreme pressure is not required to force these surfaces together. Flanges should be wide enough to prevent bulging or distorting of metal from the fused area.

Welding tips should be accurately aligned. When flat welding tip faces are used, these faces should be parallel, and should contact the material surfaces evenly over their entire areas. Domed, or slightly rounded, tip faces (about 4-inch radius) are easier to align and maintain.

The tip face diameter usually controls the size of the weld. If the tip face diameter is too small for the gauge of the metal employed, the welds may be too weak and the tips may dig into the surface of the material. If the tip face diameter is too large, a greater amount of welding current is required and the metal surrounding the weld may become overheated.

A reasonable value of tip face diameter is 0.1 inch plus twice the thickness of the thinner of the two sheets to be welded. For example: If 0.040 inch sheet is to be welded to 0.060 inch sheet, the tip face diameter should be 0.1 plus two times 0.040, or 0.180 (approximately 3/16) inch.

Tips can readily be cleaned by means of a tip cleaning pad made from a piece of wood about ¼ inch thick, 1 ½ inch wide, and 8 inches long, faced both sides with

fine abrasive cloth. Disconnect current and insert the pad between the tips, bring the tips together under light pressure and rotate the pad several times. The original diameter of the tips can be maintained by dressing the sides with a fine mill cloth.

3. Welding Pressure: Too low pressure causes surface burning and arcing, squirting out of hot metal, and porous welds. Too high welding pressure causes excessive tip marking or indentation of material surfaces, Thicker materials require higher pressures.

IMPORTANT WELDING HINTS

1. Use only welding electrodes of the specified type and shape and see that they are clean when installed. Electrodes meeting R.W.M.A. class Specifications are the most suitable for spot welding, Avoid using electrodes that are of unknown material. Use only straight electrodes except when it is physically impossible to do the job with them. Only use offset electrodes when nothing else will do the job.
2. Always check the location of the cooling tubes when installing electrodes, see that they go well up into the electrode cooling recesses.
3. Always check the flow of cooling water before starting, to the electrodes, transformer, and ignition contractor.
4. Always use the correct size hose to supply cooling water to these parts, When for any reason they must be removed they must be removed from the water connections look into the ends before reassembling to ensure against loose material that may partially block the hose.
5. Whenever there is a probability that an electrode holder will not be used for several days, remove the welding electrodes to prevent them freezing into the holder by corrosion.
6. Use fine emery cloth to dress welding electrodes. If the electrodes have deteriorated to a point where such methods are inadequate remove them for machine dressing. If you ever have occasion to instruct a mechanic relative to the machine dressing of electrodes, be sure to tell him to remove only a minimum amount of metal. Resistance welding electrodes are made from valuable alloys that should not be wasted by machining off more metal than absolutely essential to renew the contours. The use of files is not recommended for dressing electrodes, although certain contour files designed for this purpose may be used with discretion.
7. **NEVER STRIKE A CONDUCTING PART OF YOUR EQUIPMENT WITH A STEEL HAMMER.**
If there is a need for a blow to slightly move a tip holder or arm, use a rubber, rawhide, or plastic mallet, never a steel hammer.
8. If a leak develops or exists in any part of the cooling system for your equipment including the water hose connections, direct it at once to the appropriate person and request correction and instruction.
9. See that all mechanical connections in the secondary circuit of your welder are tight and clean.
10. Always perform maintenance regularly as scheduled. This includes cleaning and lubrication. Make sure that functions, assigned to others, are performed by them at specified intervals reporting any failure in

their regard to appropriate person. Remember you are responsible for your equipment, carry out your responsibilities fully but do not exceed them.

11. Keep in mind that sparks in spot welding are a sign of borderline balance between current and pressure. Among the items to check when frequent sparking or expulsion of metal from the joint is encountered is the squeeze and hold times. Material conditioning is also a factor while adequate pressure between the tips is essential to freedom from sparking. On some jobs, a minimum of sparking is difficult to prevent, in such cases make sure the slides and other vulnerable parts of your machine are protected from spark damage and above all PROTECT YOURSELF, ESPECIALLY YOUR EYES. JUST REMEMBER NO DOCTOR HAS SPARE EYES IN STOCK, YOU NOW HAVE YOUR FULL ALLOTMENT.
12. Keep the throat of your welder to the minimum possible size consistent with doing the required work. Do not extend the arms any more than necessary to obtain proper electrode forces.
13. As far as possible do not extend the metal into the throat of your machine. Remember that ferrous metals react in the throat of the machine secondary increasing their reactance which will reduce the available amperage necessary to produce the weld. When it is not possible to prevent some metal being present in the throat as the weld is made, insert the same amount of metal within the throat area as the test welds are being made to obtain comparable results.

TROUBLE SHOOTING: WELD DEFECTS AND POSSIBLE CAUSES

Symptom

Things that might cause Symptom

a.) Expulsion at Weld Inface.

1. Dirty scaly material.
2. Poor fit up.
3. Squeeze time –short.
4. Weld Force-low.

b.) Surface Expulsion Electrode Sticking.

1. Squeeze time-short.
2. Weld force-low.
3. Dirty scaly material.

c.) Electrode Mushroom

1. Weld time too long.
2. Weld forces too high.
3. Weld current high.
4. Insufficient cooling.
5. Electrode area too small.

d.) Excessive Weld Indentation

1. Weld time too long.
2. Weld forces too high.
3. Poor fit up.

e.) Little or No Weld Nugget.

1. Weld time too long.
2. Weld forces too high.
3. Weld current too low.
4. Electrode face too large.
5. Poor heat balance.
6. Welds too close together.

7. Machine not turned on weld.
8. Dirty or coated material.

f.) Cracks in Weld Nugget

1. Hold time too short.
2. Weld forces too low.
3. Dirty scaly material.
4. Poor follow up.

g.) Displaced Weld Nugget

1. Electrode misaligned.
2. Poor heat balance.
3. Poor fit up.

h.) Projection Weld Not Holding

1. Weld forces too high.
2. Weld forces too low.
3. Poor fit up.
4. Poor follow up.
5. Incorrect weld projection.

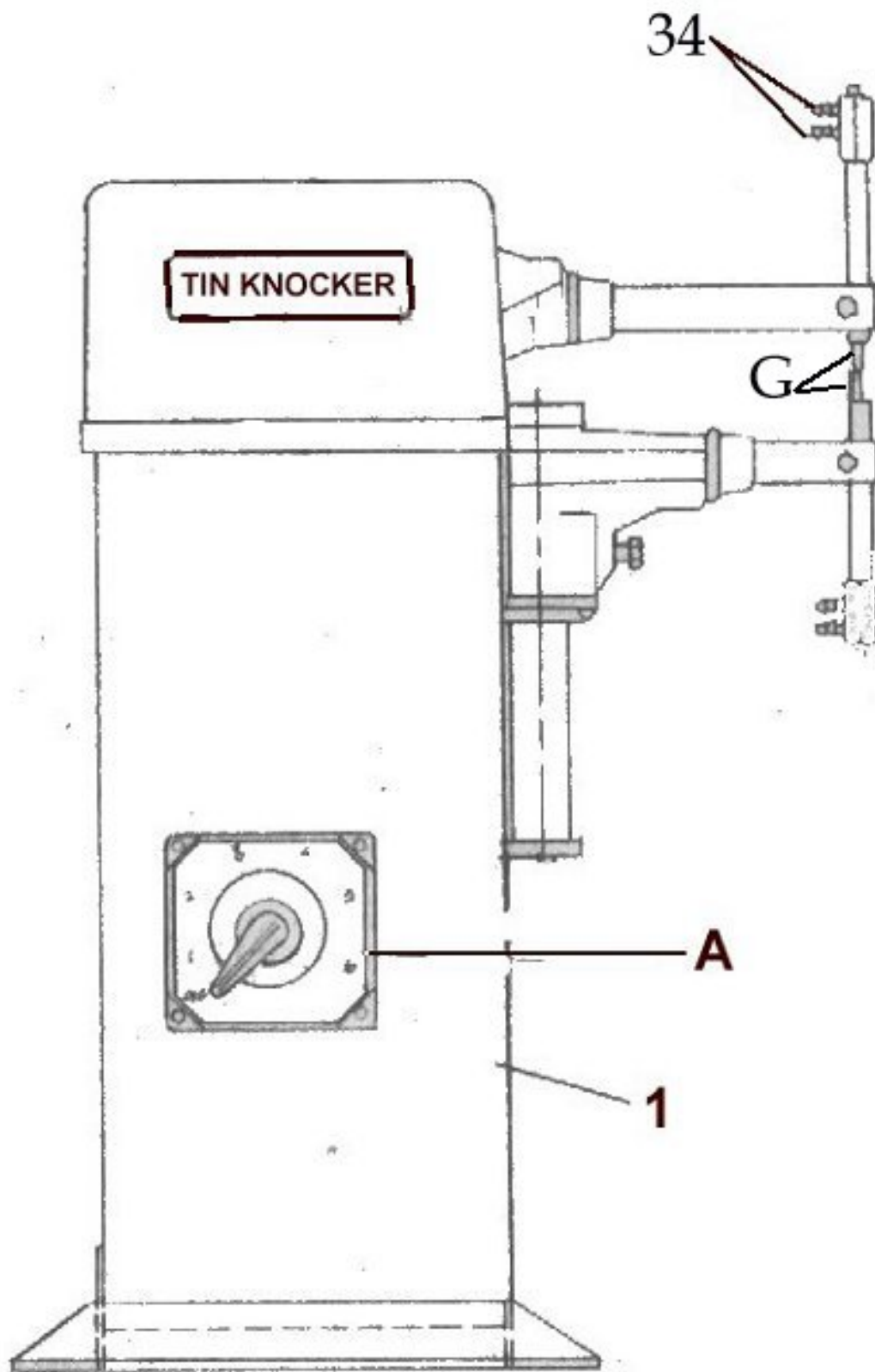

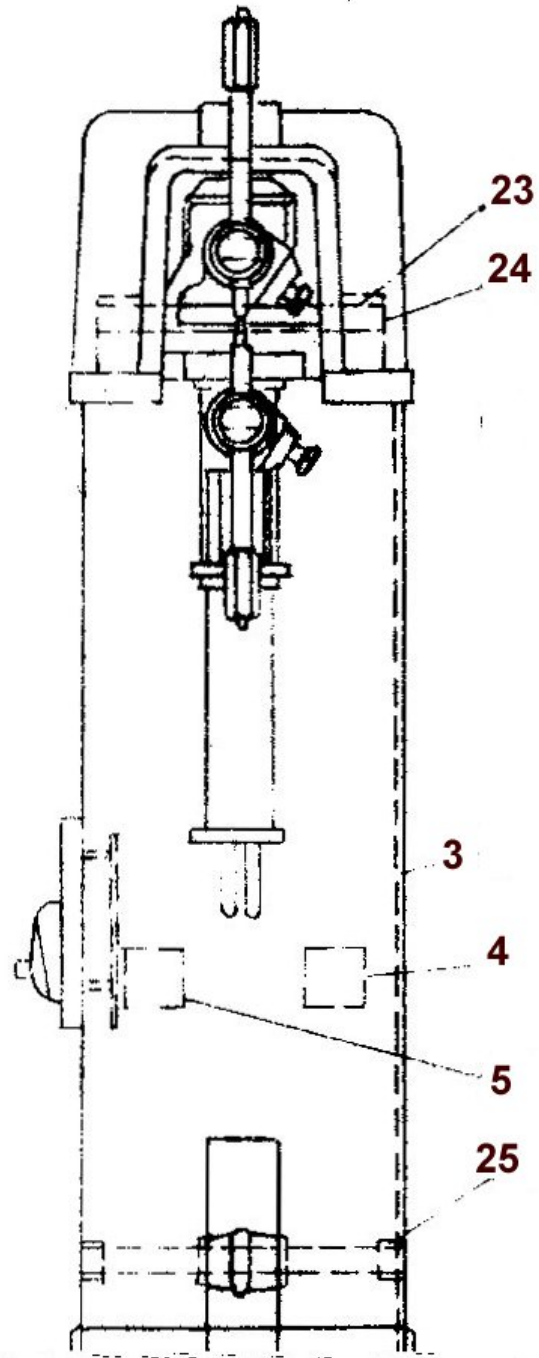

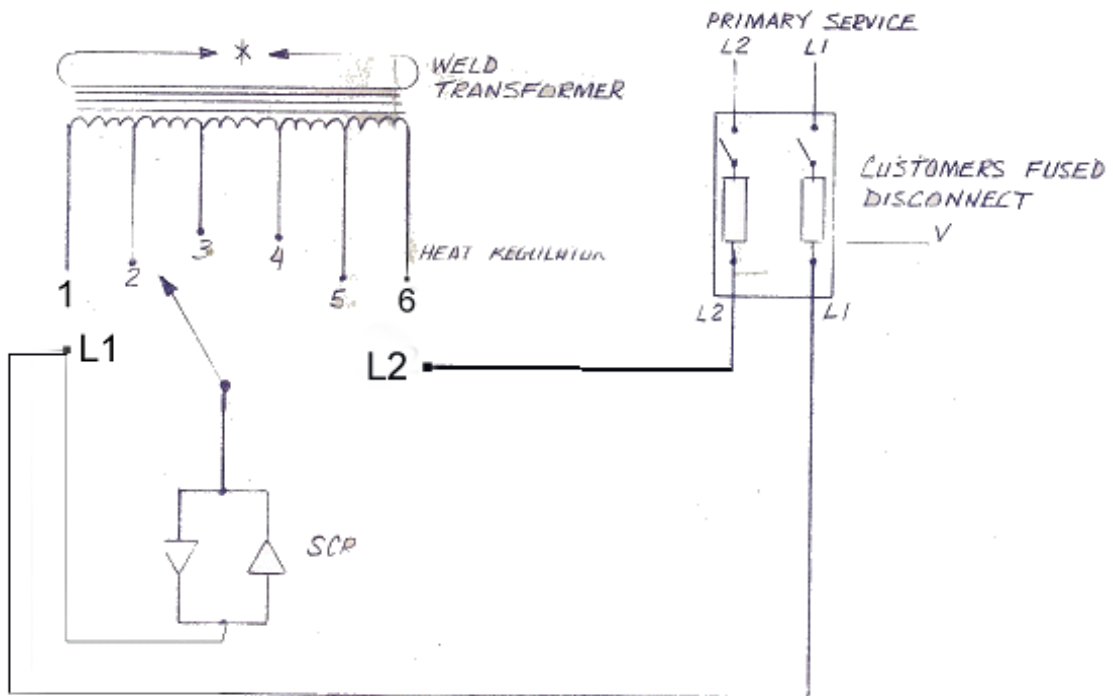
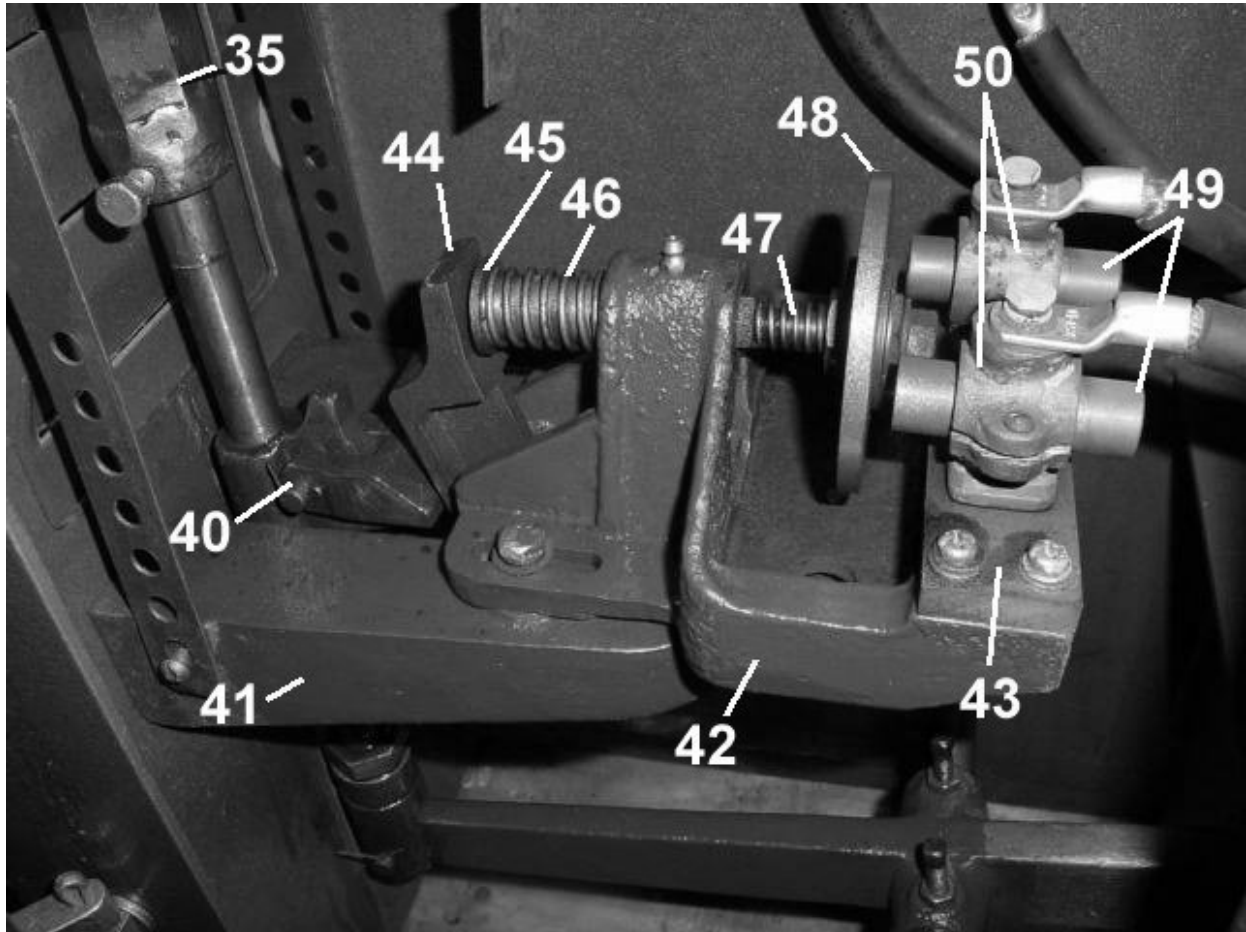

Find No.	part number	Description	No. Req'd
1	1524spot0001	Base	1
2	1524spot0002	Hood	1
3	1524spot0003	Side Cover	1
4	1524spot0004	Transformer	1
5	1524spot0005	Contacto	1
6	1524spot0006	Rear cover	1
7	1524spot0007	Column	1
8	1524spot0008	Column Gage	1
9	1524spot0009	Column Bracket	1
10	1524spot0010	Lower horn Hlr.	1
11	1524spot0011	Upper horn Hlr.	1
12	1524spot0012	Column Pad	1
13	1524spot0013	Rocker Arm	1
14	1524spot0014	Adj. Nut	2
15	1524spot0015	Horn Clp. Set Screw	2
19	1524spot0019	Horn Clp. Block	2
20	1524spot0020	Col. Clp. Set Screw	2
21	1524spot0021	Col. Clp. Block	1
22	1524spot0022	Elect. Clp Bolt	1
23	1524spot0023	Post Bronze Brg.	1
24	1524spot0024	R.A. Hinge Pin	1
25	1524spot0025	Flange Brg.	1
26	1524spot0026	Rod Exn.	1
27	1524spot0027	Treadle Hinge Pin	1
28	1524spot0028	Cleaves	1
29	1524spot0029	Comp. Spring	1
30	1524spot0030	Pin	1
31	1524spot0031	Foot Treadle	1
32	1524spot0032	Ft. Trdl. Exn.	1
33	1524spot0033	R.A. Travel Stop	1
34	1524spot0034	Water hose Nip.	4
35	1524spot0035	Comp. Spring retainer	1
36	1524spot0036	Water hose	4
40	1524spot0040	Actuating Dog	1
41	1524spot0041	Mounting Base	1
42	1524spot0042	Contacto Casting	1
43	1524spot0043	Insulator Block	1
44	1524spot0044	Striker	1
45	1524spot0045	Control rod	1

46	1524spot0046	Control rod spring	1
47	1524spot0047	Copper contact Plate spring	1
48	1524spot0048	Copper contact Plate	1
49	1524spot0049	Contact	2
50	1524spot0050	Contact Housings	2
A	1524spot0060	Heat Regulator	1
B	1524spot0061	Upper horn	1
C	1524spot0062	Lower horn	1
D	1524spot0063	Tip Holder	2
E	1524spot0064	Transformer	1
F	1524spot0065	Shunt	1
G	1524spot0066	Spotwelder tips	2
CMW	1524spot3229	Spotwelder tips	2
51	1524spot0067	Water lines, valves and fittings	1
52	1524spot0068	Center wire to contact housing	1