

# **TIN KNOCKER TK 30 POWER CLEAT BENDER**



## **INSTRUCTIONS & PARTS DIAGRAM**

**RED RIVER MACHINERY  
1-800-729-0759  
[www.redrivermachinery.com](http://www.redrivermachinery.com)**

## **WARRANTY**

All new machines are sold with a one-year limited warranty, on factory defective parts. The warranty is limited to the original user. TAAG Machinery Co. at its option, will repair, replace or refund the purchase price of any part, tool or machine that fails during the warranty period. TAAG Machinery Co. will pay normal shipping charges for replacement parts. After 90 days from date of purchase, all express or overnight delivery charges are the responsibility of the customer. Purchaser must deliver to TAAG Machinery Co., at the address below, any written claim, with proof of original purchase. Replacement parts will be invoiced to purchaser and credit issued when the failed part is delivered to TAAG Machinery Co. Removal, reinstallation or replacement parts shall be at purchasers' / user's expense. Failure due to improper use of the machine voids the warranty.

### **NOTE:**

1. This machine has been tested and adjusted prior to shipment, but can and often does require readjustment due to vibration and bouncing during transport. Following the procedures described within can easily do readjustment. These are procedures with which you, as a user, should be familiar, as you will use them repeatedly over the life use of the machine. If you have difficulty in performing these procedures, we are here to support you. Call us at: (800) 640-0746.
2. Opening rolls (for Philipsburg Lock) are consumable items and not subject to warranty

## **SPECIFICATIONS**

<b>Maximum Capacity mild steel or equivalent</b>	22 Gauge
<b>Table top height or working surface height</b>	31"
<b>Table top length not including cleat bender</b>	36"
<b>Overall length</b>	49"
<b>Maximum width capacity</b>	30"
<b>Motor</b>	1.5 HP Motor for 110 Volt, single phase 60 HZ
<b>Dimensions</b>	42" x 42" x 44"
<b>Approximate Shipping Weight</b>	650 lbs.

## **TK 30 POWER CLEAT BENDER SAFETY PRECAUTIONS**

1. Keep the work area well-lit and uncluttered to avoid accidents. Do not use compressed air for cleaning debris from yourself or the machine. Remove debris and grit from machine with a rake or brush – not your hands.
2. Machine to be operated by authorized personnel who have been trained by their supervisor with the working and safety features of the machine.
3. Thoroughly read and understand the Operator's Manual as well as the warnings and instructions mounted on the machine.
4. Notify your supervisor whenever you feel there is a hazard involving the equipment or the performance of your job.
5. Report all injuries or illness, regardless of severity, to your supervisor.
6. Do not place speed above safety.
7. Never use this machine for anything other than its intended purpose. Use the proper tool and equipment for the task.
8. Do not remove, paint over, alter, or deface any machine-mounted warning and instruction plates and signs.
9. Do not operate the machine more than its rated capacity.
10. Beware of protruding machine elements or assemblies. Avoid any pinch-points created by the movement of the machine's components.
11. Do not override the safety features of the equipment or remove any guarding.

# **TK 30 POWER CLEAT BENDER OPERATING INSTRUCTIONS**

## **RECEIVING THE MACHINE**

Upon receipt and before signing the Bill of Lading carefully examine the machine for damage that may have occurred during shipping. Be certain you have two handles. Any loss or damage should be noted in detail on the delivery receipt and reported to your distributor immediately. Free replacement from TK International is dependent upon the notation and the Bill of Lading on delivery slip.

## **INSTALLING THE MACHINE**

Place the cleat bender in a well lit area on a solid, level floor. The cleat bender must be securely bolted to a bench or a Tin Knocker stand. The bench or stand must be securely mounted to the floor. By positioning the cleat bender at the end of the worktable it is possible to bend drive cleat edges on rectangular ductwork of substantial size. Examine your clearances before bolting the machine to the bench. Be sure you have adequate room to swing both handles.

## **OPERATION**

1. Turn machine on.
2. (SET position) Press down on left foot pedal to set metal to the back-gauge fingers.
3. (Cycle) Once set, press right pedal down to bend metal.
4. Before removing the metal, ensure that machine is not in motion.
5. REPEAT or Remove metal and turn off machine.

# Full Assembly Parts Diagram

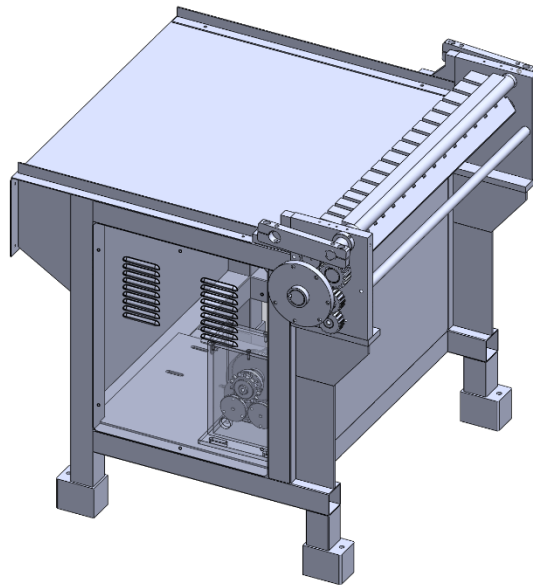
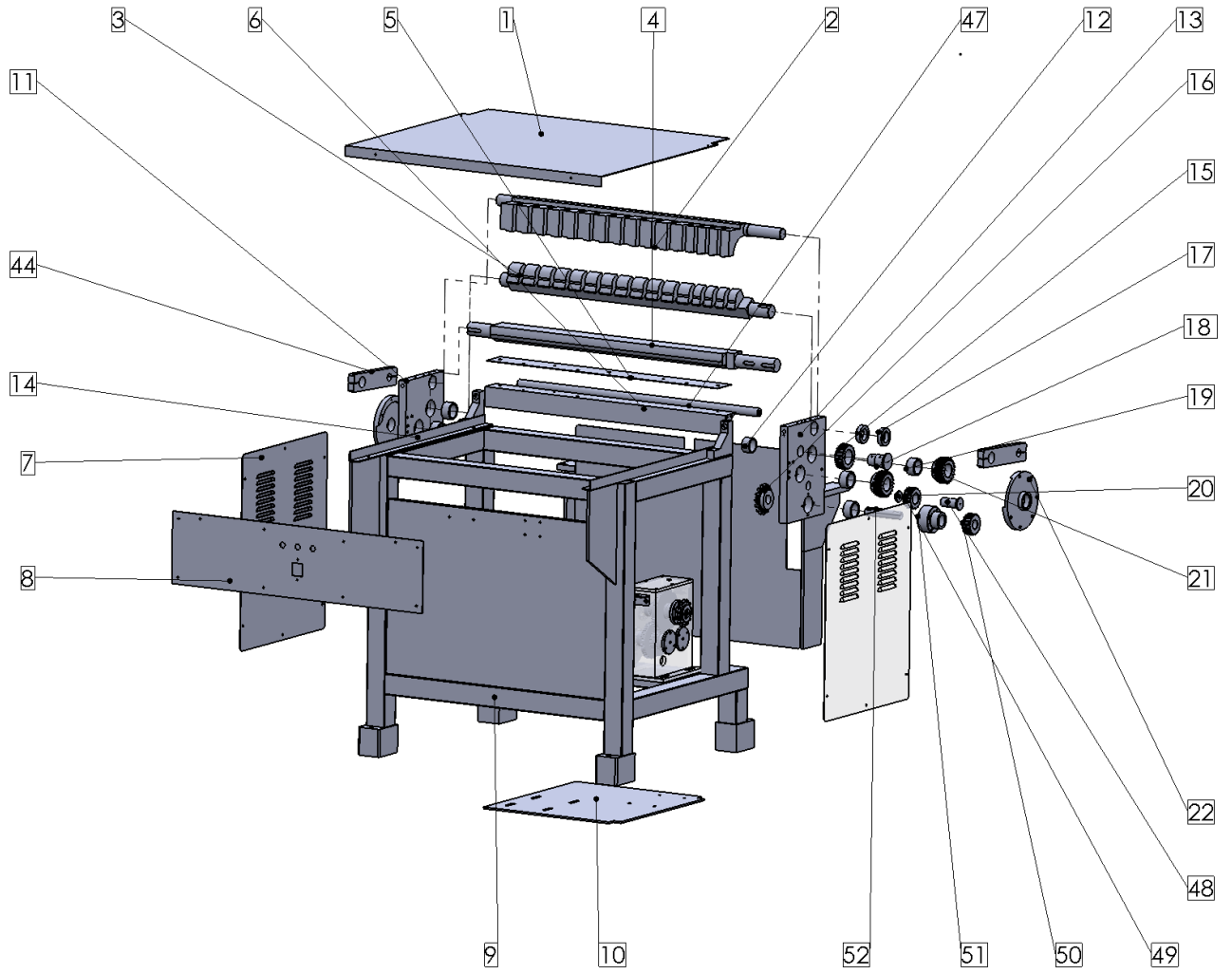

# Gear Box Parts Diagram

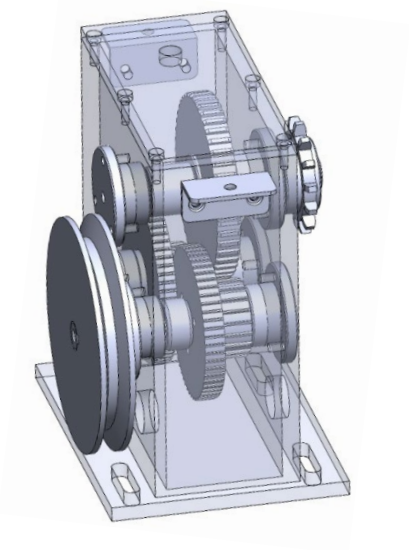
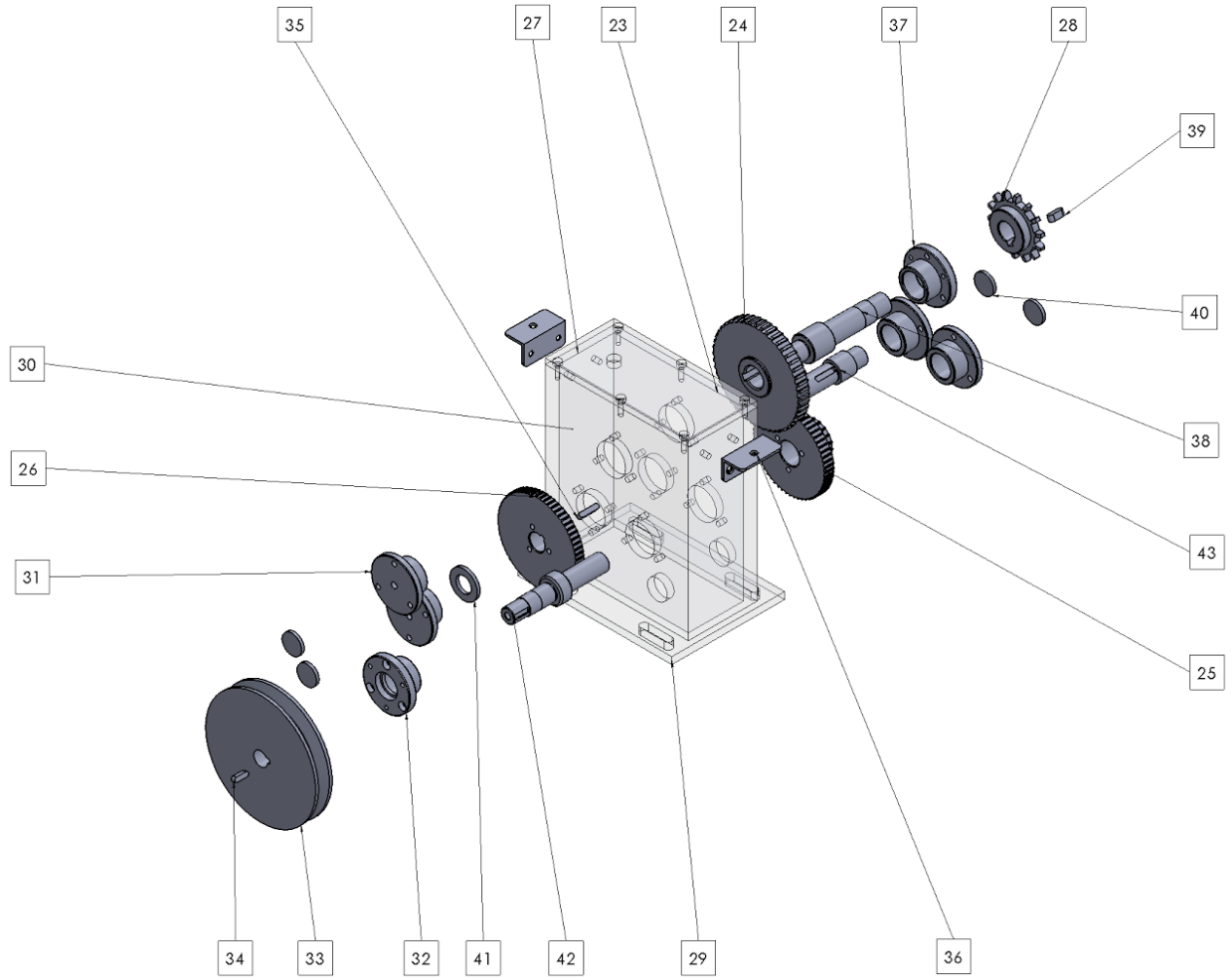

## TK 30 Power Cleat Bender Parts List

Fine No.	Part No.	QTY	Part Name
*Fine Nos. 23-43 are part of the gear box assembly (PCB074).			
*Individual parts for the gear box assembly (PCB074) are not stocked and cannot be fulfilled.			
1	PCB001	1	Steel Plate, Top
2	PCB002	1	Hold Down Fingers
3	PCB003	1	Upper Wiping Arm
4	PCB004	1	Lower Wiping Arm
5	PCB005	1	Spring Steel Plate
6	PCB006	1	Steel Bar
7	PCB007	2	Side Plate
8	PCB008	1	Upper Front Plate
9	PCB009	1	Base
10	PCB010	1	Bottom Plate (welded to Base PCB009)
11	PCB011	1	Left Side Plate
12	PCB012	4	Brass Collar (set into PCB011 & PCB013)
13	PCB013	1	Right Side Plate
14	PCB014	2	Side Angle Bar
15	PCB015	1	Gear
16	PCB016	1	Sprocket
17	PCB017	1	Collar
18	PCB018	2	Cap
19	PCB019	2	Brass Collar (set in gear)
20	PCB020	1	Washer
21	PCB021	1	Gear
22	PCB022	2	Cam assembly (limit switch plate must be 2 inches long)
23	See PCB074	1	Top Gear Box Plate
24	See PCB074	1	Large Right Side Gear
25	See PCB074	1	Right Side Gear
26	See PCB074	1	Left Side Gear
27	See PCB074	2	Side Gear Box Plate
28	See PCB074	1	Gear box sprocket
29	See PCB074	1	Bottom Gear Box Plate
30	See PCB074	2	Front Gear Box Plate
31	See PCB074	2	Left Side Cap
32	See PCB074	1	Left Side Large Cap
33	See PCB074	1	Left Pulley
34	See PCB074	1	Pin
35	See PCB074	1	Pin
36	See PCB074	2	Angle Support Piece

37	See PCB074	3	Right Side Cap
38	See PCB074	1	Right Shaft
39	See PCB074	1	Key
40	See PCB074	4	Pulley
41	See PCB074	1	Washer
42	See PCB074	1	Left Side Shaft
43	See PCB074	1	Right Lower Shaft
44	PCB044	2	Clamping Arm assembly
45	PCB045	1	Motor
46	PCB046	1	Foot Pedal
47	PCB047	1	Connecting Bar
48	PCB048	1	Cap
49	PCB049	1	Gear
50	PCB050	1	Gear
51	PCB051	1	End Cap
52	PCB052	1	Shaft
Not Shown	PCB053	1	cam cover left
Not Shown	PCB054	1	cam cover right
Not Shown	PCB055	1	spring bar
Not Shown	PCB056	1	back plate
Not Shown	PCB057	4	10mmX9mm key (various lengths)
Not Shown	PCB058	4	35mmX8mm Peg
Not Shown	PCB059	2	8mmX8mm key
Not Shown	PCB060		3/8" ID dock washer
Not Shown	PCB061		1/2" ID dock washer
Not Shown	PCB062		1.25" ID, 2" OD brass washer
Not Shown	PCB063		1.4" ID, 2" OD brass washer
Not Shown	PCB064		1.5" ID, 2" OD brass washer
Not Shown	PCB065	1	1" ID, 1.75" OD brass washer
Not Shown	PCB066		3/8" X 1.5" socket head bolt
Not Shown	PCB067		3/8" X 1.2" socket head bolt
Not Shown	PCB068		5/16" X 1" socket head bolt
Not Shown	PCB069		6mm X 41mm socket head bolt (thinnest)
Not Shown	PCB070		3/8" X 0.7" socket head bolt
Not Shown	PCB071		12mm grease port bolt
Not Shown	PCB072		8mm bolt
Not Shown	PCB073	6	grease port (not including grease port bolt)
Page 5	PCB074	1	gear box assembly
Not Shown	PCB075	1	drive chain