

TIN KNOCKER
24 GA. PITTS ROLLFORMER

INSTRUCTIONS & PARTS DIAGRAM



Shown with Stand and Optional Flanging Attachment

RED RIVER MACHINERY
1-800-729-0759
www.redrivermachinery.com

TIN KNOCKER

SAFETY RULES

PITTSBURGH ROLL FORMER

1. **WARNING:**

Electrical Danger---Misuse or improper installation of machinery connected to a source of electricity may result in accidental shock that could cause injury or death. Installation must conform to National Electric Code (Article 250-Grounding, etc.)

A trained and qualified electrician must make electrical connections. Electrical characteristics shown on motor plate and control panel must match the power source; and all electrically powered equipment must be grounded.



2. **WARNING:**

Mechanical Danger- The power driven forming rolls rotate at all times when power is supplied to the motor. Never place any part of the body including loose clothing near or onto the rotating rolls. (KEEP HANDS AWAY). Failure to comply will lead to personal body injury.



3. Never clean forming rolls while rolls are rotating—turn power off to clean rolls.
4. Machine to be operated by authorized personnel who have been trained by their supervisor with the working and safety features of the machine, and by reading and understanding the Operator's Manual.
5. Do not operate Roll former without reading operator's Manual and without proper supervisory instructions.
6. Perform all installation and set-up operations before applying power for electrical start-up.
7. Never operate machine with any guard removed; i.e., all required guarding to be installed and effective. Do not override the safety features of the equipment. Do not remove, paint over, alter, or deface any machine-mounted warning and instruction plates and signs.
8. Never leave machine running unattended. When not in use, turn off electrical power.
9. Never adjust machine with power on. Avoid accidental start-up.
10. Do not use machine if servicing is required.
11. Use safety glasses and required protective tools.
12. Keep work areas clean and in proper order.
13. Be alert to all potential hazards. Notify your supervisor whenever you feel there is a hazard involving the equipment or the performance of your job.

WARRANTY

All new machines are sold with a one-year limited warranty, on factory defective parts. The warranty is limited to the original user. TAAG Machinery Co. at its option, will repair, replace or refund the purchase price of any part, tool or machine that fails during the warranty period. TAAG Machinery Co. will pay normal shipping charges for replacement parts. After 90 days from date of purchase, all express or overnight delivery charges are the responsibility of the customer. Purchaser must deliver to TAAG Machinery Co., at the address below, any written claim, with proof of original purchase. Replacement parts will be invoiced to purchaser and credit issued when the failed part is delivered to TAAG Machinery Co. Removal, reinstallation or replacement parts shall be at purchasers' / user's expense. Failure due to improper use of the machine voids the warranty.

NOTE: 1. This machine has been tested and adjusted prior to shipment, but can and often does require readjustment due to vibration and bouncing during transport. Following the procedures described within can easily do readjustment. These are procedures with which you, as a user, should be familiar, as you will use them repeatedly over the life use of the machine. If you have difficulty in performing these procedures, we are here to support you.

2. Opening rolls (for Philipsburg Lock) are consumable items and not subject to warranty.

OPERATING INSTRUCTIONS

Holding the material against the angle guide, slide it in to the forming head. Be sure that the material remains against the guide until work is finished.

Make "hold-down adjustment" to meet any variation in the material of your locality. **DO NOT ADJUST** unless material slips, tends to leave guide, or curls up at finish. If the material slips, tighten the studs equally until the condition is overcome. It is very important that long sheets be fed in to the machine flat and against the guide for the start.

IMPORTANT: If proper care is taken, the small knife edge roll that holds the pocket of the Pittsburgh Lock open will not break. If burrs and twists from snip cuts are not flattened out, it will sometimes strike against the opening roll, causing it to break. (Reminder: opening rolls are consumable and not subject to warranty.)

SPECIFICATIONS

GENERAL: Recess for Pittsburgh Lock Flange is 5/16" deep

Hammer-over edge adjustable for width

Uses about 7/8" of material

One piece Pittsburgh Lock rolls, gears and shafts

FORMING UNIT: Hardened and ground steel shafts, precision made case

hardened steel forming rolls, machine cut gears

CAPACITY: 24 gauge and lighter

MOTOR: Standard equipment 1/2 H.P., 110-220 Volts, 60 cycle, single phase,

A.C., plugs in to regular light socket (other types available)

DRIVE: Single V belt

STAND: Arc-welded steel construction finished in green machinery enamel, heavy top plate

DIMENSIONS: 30" long, 14" wide, 16 1/2" high overall including Power Flanger,

12" high without flanger, cabinet height 8"

WEIGHT: Rollformer 165 lbs. Stand 40 lbs.

ROLLER BEARINGS THROUGHOUT:

POWER FLANGER makes 7/32" Right Angle Flange on either straight or curved pieces to a radius as small as 1 3/4". It is fitted with an adjustable guide, which can be set to hold metal to the gauge and automatically turn a flange to a given radius or a straight line.

LUBRICATION

The slow speed shafts do not require lubrication. Rolls should be sprayed daily with a galvanize remover to prevent build up of galvanized material on the rolls.

24-GAUGE ASSEMBLY

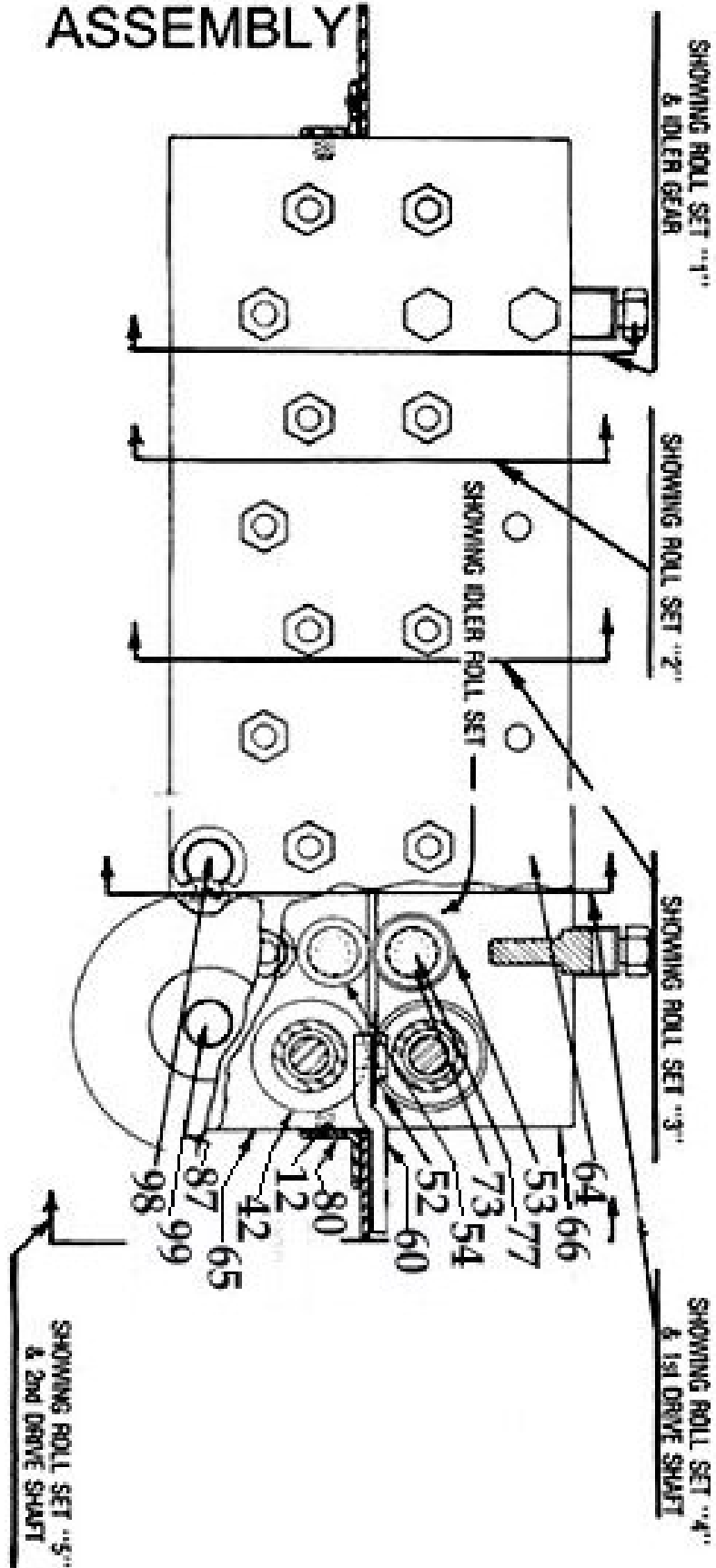

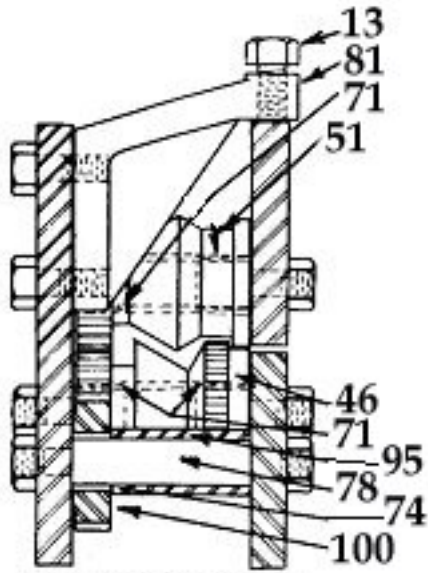

SHOWING ROLL SET "1"
& IDLER GEAR

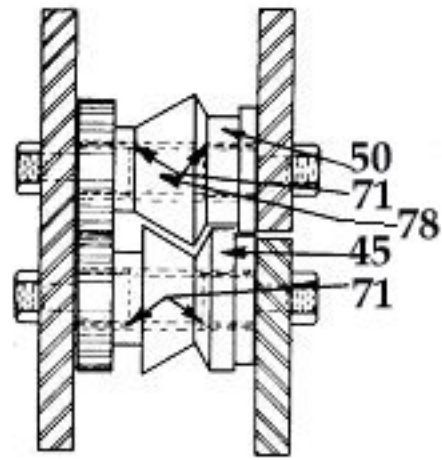

SHOWING ROLL SET "2"

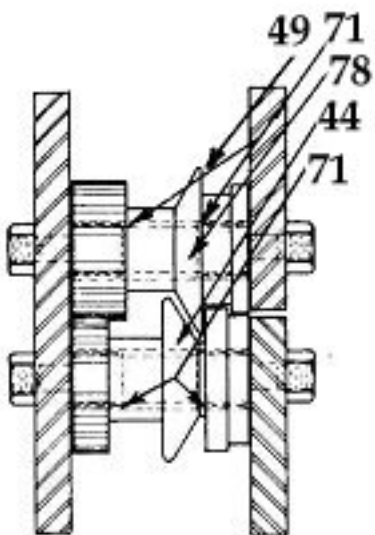

SHOWING ROLL SET "3"

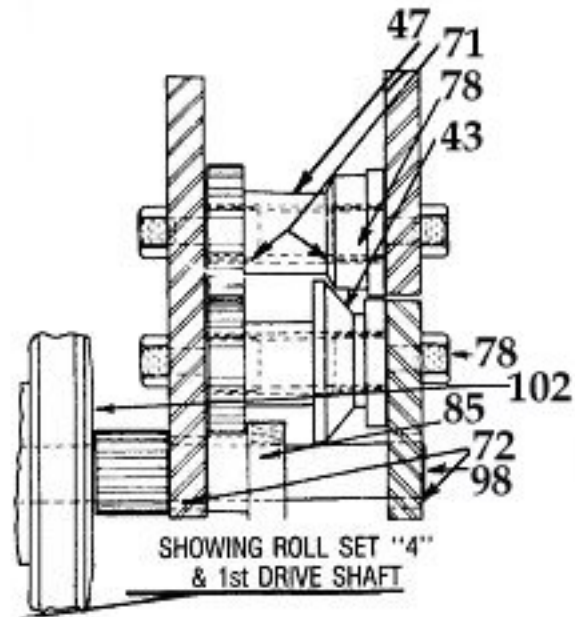

SHOWING ROLL SET "4"
& 1st DRIVE SHAFT

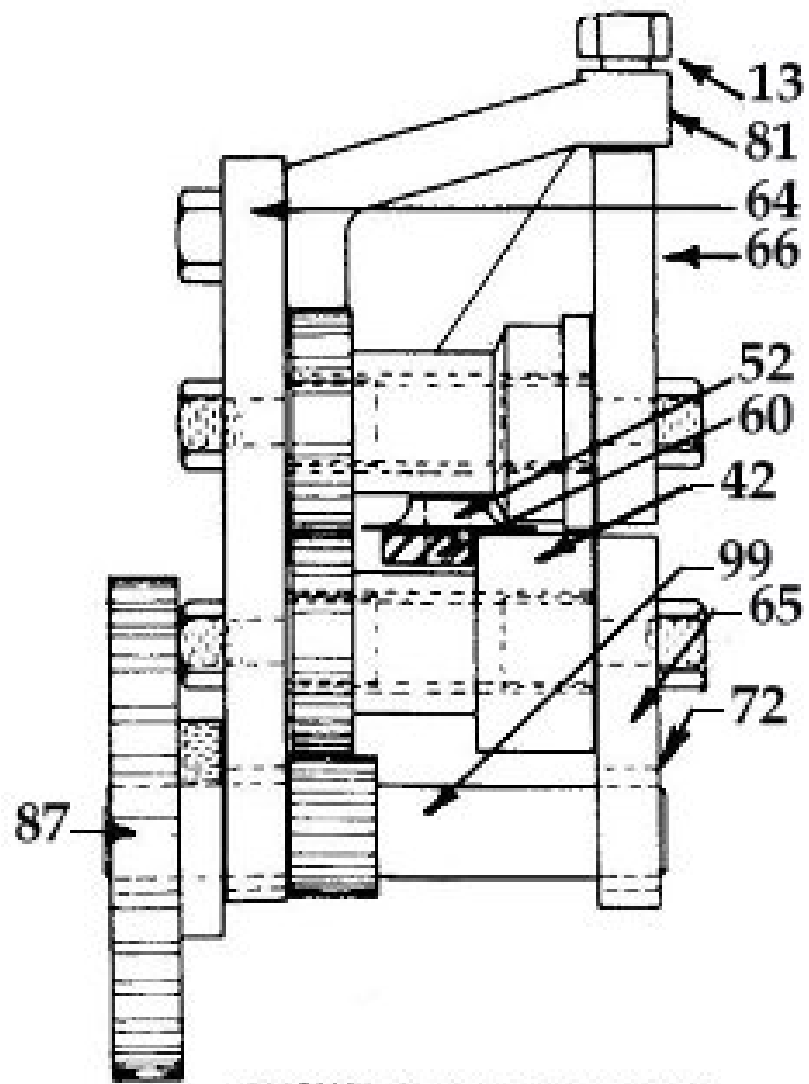

SHOWING ROLL SET "5"
& 2nd DRIVE SHAFT



69



91

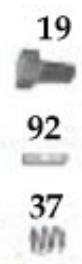

19

92

37



83



88



89



94



55



56



70



35



104



57

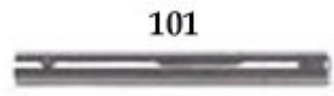

101



71



24



58

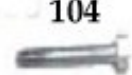

104



90



74



27



29



20



3



36



79



21



62



33



34



11

93



97



86



28



63

PARTS LIST AND DESCRIPTION

Parts For 24 Gauge Pitts

Fine No.	Part No.	Description	No. REQ"D.
1	24P66040	Bearing Idler Roll	
2	24P600123935	#9 Woodruff Key	2
3	24P600123936	Key 4.76 SQ. x 38.1 mm	1
4	24P660000486	Cord 14-3 x 10 Ft.	1
5	24P660011240	1/2 Hp 1 60 18 56	1
6	24P660082164	Toggle Switch 82070	1
7	24P660172838	Sta. Kon Connector B14250	2
8	24P660172839	BX Connector ½	2
9	24P660172840	Insulating Cap	2
10	24P660172841	Wire Joint	2
11	24P695000600	Gauge Dial	1
12	24P695012772	Hex Bolt M8-1.25 x 15 mm	6
13	24P695012773	Hex Bolt M10-1.5 x 50 mm	2
14	24P695012774	Hex Bolt M8-1.25 x 20 mm	6
15	24P695012775	Hex Socket Set Screw M8-1.25 x 10 mm	1
16	24P695012776	Hex Socket Set Screw M10-1.5 x 10 mm	8
17	24P695012777	Hex Socket Set Screw M6-1 x 10 mm	3
18	24P695012778	Drive Screw 101.6 x 4.7625 mm	2
19	24P695012779	Thumb Screw M10-1.5 x 25 mm	1
20	24P695012781	Phillips Head Stove Bolt M6-1 x 15 mm	4
21	24P695012783	Hex Socket Set Screw M8-1.25 x 10 mm	3
22	24P695012784	Phillips Head Stove Bolt M8-1.25 x 20 mm	4
23	24P695012785	Hex Bolt M10-1.5 30 mm	4
24	24P695023076	Hex Nut M12-1.75	1
25	24P69502377	Jam Nut M10-1.5	2
26	24P695023078	Lock Nut M10-1.5	28
27	24P695033190	Lock Washer 10 mm	4
28	24P695033191	Steel Washer 15.875 x 1.5875 mm	2
29	24P695033192	Washer 9.525 x 1.5875 mm	2
30	24P695033193	Lock Washer 8 mm	12
31	24P695033194	Brs. Washer 19.05 x 0.7874 mm	4
32	24P695033195	Washer 8 x 1.5875 mm	8
33	24P695053393	Dowel Pin 9.525 x 19.05 mm	1
34	24P695053394	Dowel Pin 11.1125 x 38.1 mm	1
35	24P695053395	Dowel Pin 15.875 x 57.15 mm	1
36	24P695184619	Spring – Compression	1
37	24P695184620	Compression Spring 3/8 ID	1
38	24P695265332	4 L 500 Belt	1
39	24P695346288	Name Plate	1
40	24P695346289	Lf. Cap Name Plate	1
41	24P695346290	Logo	1
42	24P795000004	Bottom Forming Roll B5	1

43	24P795000005	Bottom Forming Roll B4	1
44	24P795000006	Bottom Forming Roll B3	1
45	24P795000007	Bottom Forming Roll B2	1
46	24P795000008	Bottom Forming Roll B1	1
47	24P795000009	Top Forming Roll T4 &T5	1
48	24P795000009B	Top Forming Roll T5	1
49	24P795000010	Top Forming Roll T3	1
50	24P795000011	Top Forming Roll T2	1
51	24P795000012	Top Forming Roll T1	1
52	24P795000022	Opening Roll	1
53	24P795000029	Upper Idler Roll (need 1 B812 Tor)	1
54	24P795000030	Lower Idler Roll (need 1 B812 Tor)	1
55	24P795000044	Knurled Forming Roll	1
56	24P795000045	Plain Forming Roll	1
57	24P795000047	Inner Race Assembly	1
58	24P795000050	Adjustable Guide Roll	1
59	24P795000061	Sensory Casting	1
60	24P795010017	Opening Roll Hldr Assbly/ EXIT GUIDE BAR	1
61	24P795030003	Feed Gauge Bar	1
62	24P795030053	Compensator Arm	1
63	24P795030054	Tension Spring Push Rod	1
64	24P795060000	Back Housing Plate	1
65	24P795060001	Lower Front Housing Plate	1
66	24P795060002	Upper Front Housing Plate	1
67	24P795060033	Stand Assembly	1
68	24P795060036	Toggle Switch Plate	1
69	24P795060037	Cast Iron Base	1
70	24P795060046	Spacer Plate	1
71	24P795080020	Bearing B1012 Torr	20
72	24P795080021	Bearing B128 Torr	4
73	24P795080023	Bearing B812 Torr	2
74	24P795080024	Bearing B108 Torr	4
75	24P795080057	Bearing	1
76	24P795090055	Forming Table	1
77	24P795160031	Idler Roll Pin	2
78	24P795160032	Spacer Stud	14
79	24P795160058	61 Woodruff Key Modified	1
80	24P795180018	Machine Support	2
81	24P795200019	Bracket Cast	2
82	24P795220034	Cover Assembly	1
83	24P795220040	Cover	1
84	24P795220056	Removable Cover	1
85	24P795260026	Thrust Collar	1
86	24P795260062	Collar 15.875 mm	1
87	24P795380015	Gear Driven with Hub	1
88	24P795380041	Gear Bevel	1
89	24P795380042	Gear Comb. Spur & Bevel	1

90	24P795380051	Gear	2
91	24P795490038	Steel Forming Head	1
92	24P795530039	Special Machine Key -Concave	1
93	24P795560059	Tension Screw Nut M27-2	1
94	24P795570043	Lifter Plug	1
95	24P795630025	Spacer	3
96	24P795630063	Spacer Step	1
97	24P795650060	Tension Screw M27-2	1
98	24P795680013	1st Drive Shaft w/integral Gear	1
99	24P795680014	2nd Drive Shaft w/integral Gear	1
100	24P795680027	Idler Gear (need 1 B128 Tor)	4
101	24P795680032	Spacer Stud	
102	24P795680048	Roll Shaft	1
103	24P795710016	Sheave Machine 9-1/8"	1
104	24P795710035	2 A5 23 5/8 Sheave	1
105	24P6955012780	Hex Bolt M10-1.5 x 40 mm	2
106	24P7950610001	24 GA (no Flanger Cover)	

TO INSTALL POWER

FLANGING ATTACHMENT

1. Remove top cover by removing the two hold-down studs and lifting the cover from the machine.
2. Replace the two hold-down studs and adjust.
3. Set the flanging attachment over the forming head so that the combination bevel and spur gear meshes with the Pittsburgh Lock roll No. 3.
4. Place the two 3/8" x 11/4" Hex-Head cap screws and lock washers into flanging attachment mounting holes and tighten.

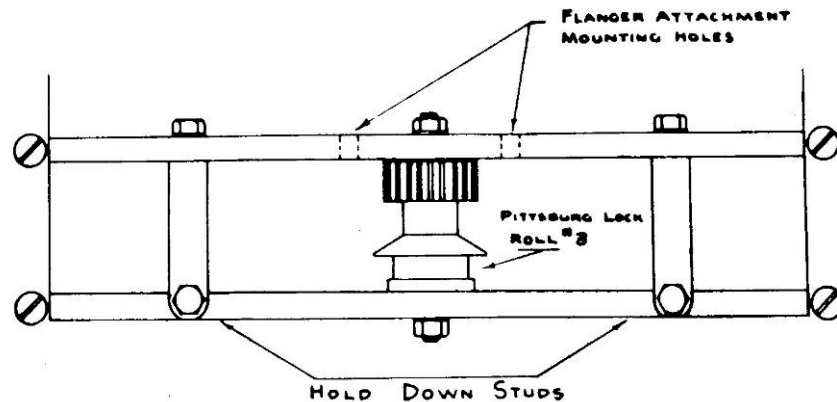

TO OPERATE POWER FLANGING ATTACHMENT

ADJUST UNIT FOR GAUGE MATERIAL TO BE USED To adjust clearance between flanging rolls, tighten the adjusting screw on the front of the block of the machine all the way, then loosen the screw approximately one eighth of a turn. (This setting is usually correct for 26 gauge material.) Do not set front gauge adjusting screw too tight. It should be set just tight enough to draw the metal through the rolls. Too tight a setting will stretch and wrinkle the material.

To adjust the spring tension on the compensator arm, tighten the adjusting dial on the backside of the flanger to the stop and then turn back to the proper gauge setting shown on the adjusting dial.

TURN UP A “STARTING FLANGE” on the material before inserting it into leading edge of the work to be flanged in the slot cut into the table and bending the piece away from the operator approximately 45 degrees. Start the leading edge of the material into the rolls. As the material passes through the rolls, the compensator arm will make contact with the material and guide it through the rolls. If the material pulls out of the rolls, it is an indication that either the front adjusting screw is too loose or the back adjusting dial is not tight enough.

IMPORTANT. When starting a partially formed section that contains an inside curve, push the compensator arm back until it locks out of position. Feed partially formed section into the rolls and the machine will pull the material through. As the rolls approach the section that is not formed, bring the compensator arm to the material holding the spring tension off the piece until the unformed section comes to the rolls; then bear pressure to the piece until the flange picks up, then release compensator arm so that “automatic” guiding is resumed.

