

# TIN KNOCKER

## TK 1655 NOTCHER

### INSTRUCTIONS & PARTS DIAGRAM



RED RIVER MACHINERY  
1-800-729-0759  
[www.redrivermachinery.com](http://www.redrivermachinery.com)

## **WARRANTY**

All new machines are sold with a one-year limited warranty, on factory defective parts. The warranty is limited to the original user. TAAG Machinery Co. at its option, will repair, replace or refund the purchase price of any part, tool or machine that fails during the warranty period. TAAG Machinery Co. will pay normal shipping charges for replacement parts. After 90 days from date of purchase, all express or overnight delivery charges are the responsibility of the customer. Purchaser must deliver to TAAG Machinery Co., at the address below, any written claim, with proof of original purchase. Replacement parts will be invoiced to purchaser and credit issued when the failed part is delivered to TAAG Machinery Co. Removal, reinstallation or replacement parts shall be at purchasers' / user's expense. Failure due to improper use of the machine voids the warranty.

**NOTE: 1.** This machine has been tested and adjusted prior to shipment, but can and often does require readjustment due to vibration and bouncing during transport. Following the procedures described within can easily do readjustment. These are procedures with which you, as a user, should be familiar, as you will use them repeatedly over the life use of the machine. If you have difficulty in performing these procedures, we are here to support you.

2. Opening rolls (for Philipsburg Lock) are consumable items and not subject to warranty.

## **TIN KNOCKER SAFETY RULES TK 1655 NOTCHER**

1. Never use a machine or tool for anything other than its intended purpose. Use the proper tool and equipment for the task.
2. Do not operate the machine in excess of its rated capacity.
3. Keep hands away from blade areas while notching, because the notching blades are sharp metal cutting devices that are capable of personal injury.
4. The material thickness being notched should be within the rating of the hand notcher otherwise damage to the hand notcher or personal injury may occur.
5. Mount hand notcher securely to a solid work bench prior to use and work bench must be secured to the floor

# TK 1655 NOTCHER

## RECEIVING THE MACHINE Inspect before signing Bill of Lading.

Upon receipt closely examine the 1655 Notcher for damage during shipment. Be certain you have handles. Any loss or damage should be noted in detail on the delivery receipt and reported to your distributor immediately. Free replacement from TK International is dependant upon the notation and the Bill of Lading on delivery slip.

## INSTALLING THE MACHINE

The TK 1655 Notcher removes and trims sheet metal 16 gauge and lighter to form all kinds of special shapes. Heavy-duty bearings give smooth operation. Ram with adjustable gibs assures blade alignment. Lower blade adjusts quick and easy. A 6" scale is set on each side of the lower 90° blade and an adjustable gauge is mounted on each scale for fast, simple set-ups on duplicate notching jobs. Floor stand is available.

## OPERATING THE MACHINE

Blades have two cutting edges and may be rotated when dull. Upper blades are interchanged from one side of ram to the other. The lower blades are interchanged from one side of the base to the other and turned over. Blades may be sharpened by grinding the edge. The face may be ground if necessary and shims must be used under blades to compensate for amount ground off. It is important that the blades be ground the same amount and the lower blades adjusted to compensate for this grinding.

## LUBRICATION

Oil ram slide and cam daily.

## SPECIFICATIONS:

Standard equipment includes one set 90° blades.  
Capacity, mild steel...6"x 6"x90° notch in 16 ga.  
Weight without floor stand.....110 lbs.  
Weight with floor stand.....145 lbs.

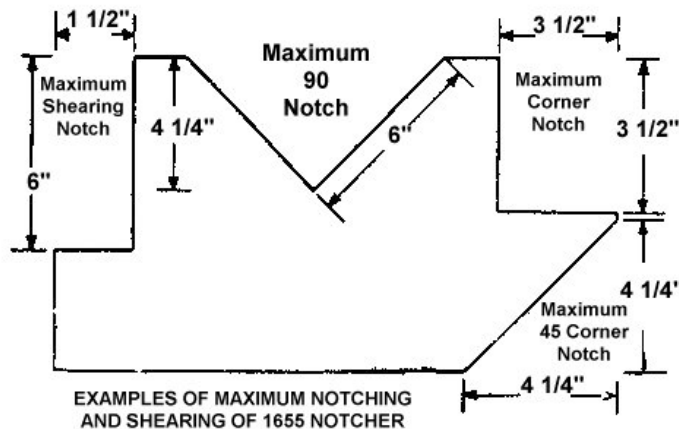

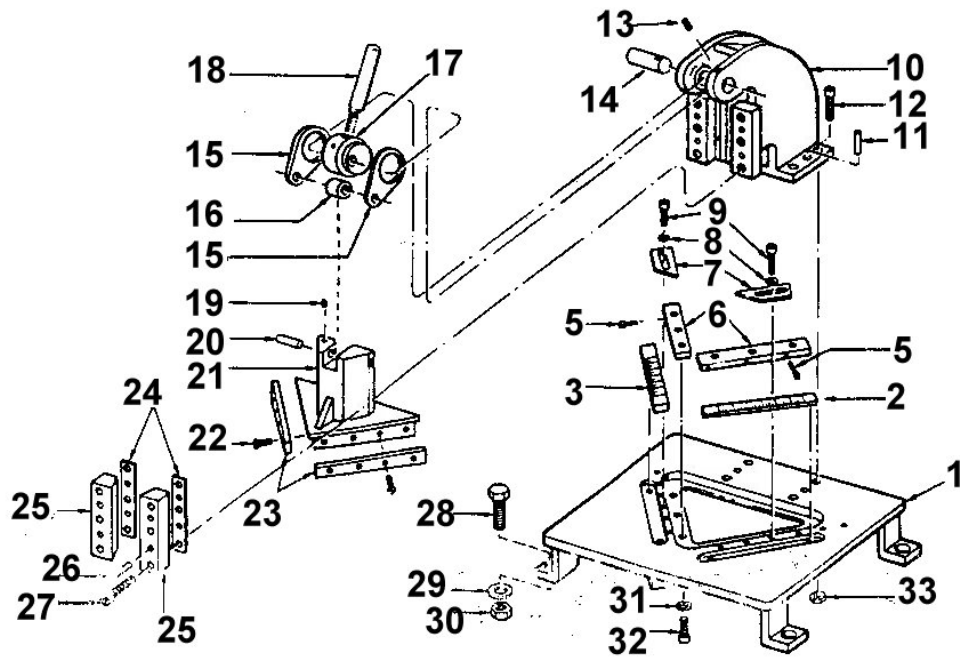
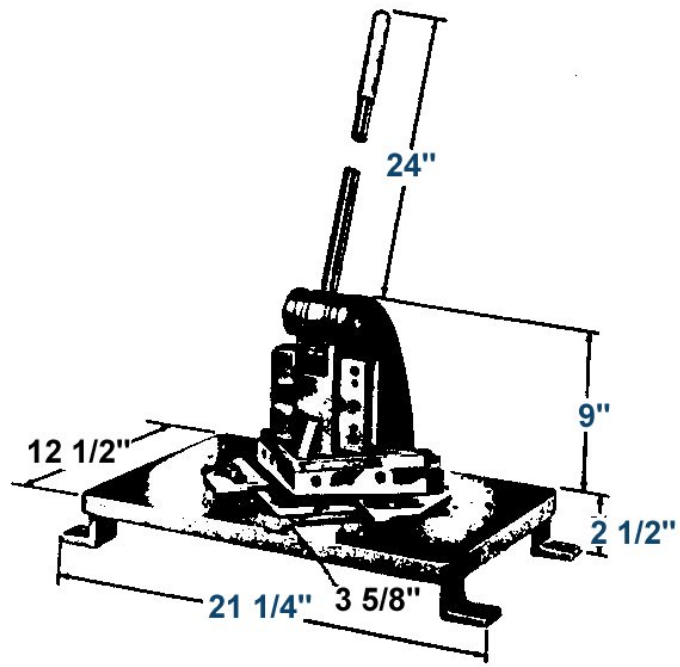

## Parts For 1655 Notcher

Fine No.	Part No.	Description	No. REQ"D.
1	NOT1655001	Notcher Base (Table)	1
2	NOT1655002	R.H. Table Scale	1
3	NOT1655003	L.H. Table Scale	1
5	NOT1655005	Lower Blade Adjusting Screw	6
6	NOT1655006	Lower Blade Set (2 Piece)	1 set
7	NOT1655007	Table Gauge	2
8	NOT1655008	Gauge Screw Washers (Flat)	2
9	NOT1655009	Table Gauge Screws	2
10	NOT1655010	Notcher Frame (Head)	1
11	NOT1655011	Head & Table Pins (Taper)	2
12	NOT1655012	Head & Table Bolts	4
13	NOT1655013	Operating Handle Cam Pin Set Screw	1
14	NOT1655014	Operating Handle Cam Pin	1
15	NOT1655015	Side Links	2
16	NOT1655016	Roller Bearing Complete	1
17	NOT1655017	Cam	1
18	NOT1655018	Operating Handle	1
19	NOT1655019	Roller Bearing Pin Set Screw	1
20	NOT1655020	Roller Bearing Pin	1
21	NOT1655021	Ram	1
22	NOT1655022	Upper Blade Screws	8
23	NOT1655023	Upper Blade (2 Piece)	1 Set
24	NOT1655024	Gib Shims	2
25	NOT1655025	Ram Gibs	2
26	NOT1655026	Gib Pins Taper	4
27	NOT1655027	Gib Screws	6
28	NOT1655028	Stand Bolts	4
29	NOT1655029	Stand Bolt Washers (lock)	4
30	NOT1655030	Stand Bolt Nuts	4
31	NOT1655031	Lower Blade Mounting Bolt Washer	6
32	NOT1655032	Lower Blade Mounting Screw	6
33	NOT1655033	Head & Table Bolt Nuts	4