



A660 bronze bearings guaranteed for 5 years based on a 24 hour workday. These bearings easily last 15-20 years and the bronze material is always readily available.

RED RIVER MACHINERY INC
2601 N. INTERSTATE HWY 45 ENNIS, TX 75119
1(800) 229-0759
<https://www.redrivermachinery.com/>

80,000 P.S.I. Rated Steel Capacity

Under 3,000 P.S.I. system pressure that provides substantially longer system life.



Extremely heavy-duty hold downs. Fewer hold downs = less maintenance. Hold down pressure is adjustable for your sensitive material.



Incredibly strong gusseted table providing decades of reliable performance



Extremely heavy duty, precision tables designed to provide the least amount of deflection and to last generations.

For 100% *U.S. Quality*

Complete O.S.H.A. and
ANSI B11.4 Compliance



Shadow light for precise
shearing line

Lifetime Parts Availability:

Every component on machine is
available from your local suppliers giving
you a lifetime of productivity and parts

LONGEVITY:

5 Year parts warranty based on a 24 hour workday
+
Typical 25-30 year lifetime
+
100% Made in the U.S.A.

Standard = Longevity

Positive mechanical
tapered gibbs for
smooth uniform
gap adjustment

Easy to understand mechanical gap
indicators showing exact gap
placement and infinite adjustment



Incredibly simple, easy to troubleshoot
hydraulic system is fully covered by our
5 year warranty and is comprised of all
readily available components

Guillotine Drive **vs.** Swingbeam/Rocker Arm Drive

Ask a professional fabricator and they will tell you there is no substitute for an American made, true guillotine drive system when shearing. Lower quality, typically foreign made swingbeam/rocker arm style competitors attempt to compare themselves to a guillotine but all fail. No other shear design can compare when it comes to the power and precision delivered by the straight line cutting action of a Standard shear.

4 Crucial Factors to Provide the Most Precise Cut

- (1) Strength of the drive system
- (2) Strength of the frame
- (3) Consistent angle of the upper blade to the work piece throughout the cut
- (4) A heavy duty, high tonnage hold down system to hold work piece

Guillotine

The most important factor in providing a precision cut is the manner in which the upper blade cuts through material from the beginning to the end of the cut. A Standard guillotine drive system insures the upper blade comes down in a straight line because the linkage is driven from directly above the workpiece. Throughout the cut the relationship of the upper blade to the material never changes.

↓
F
O
R
C
E
↓

Swingbeam/Rocker Arm

In direction opposition to this, the swingbeam/rocker arm system pivots from the side of the end frames and brings the ram down in an arc or “swing”. This causes the relationship of the top blade to the work piece to change throughout the entire cut. Because the blade comes down in an arc, the cut is distorted throughout the cut.

R
O
C
K
E
↓

For 100% U.S. Performance

Standard Industrial Guillotine Drive System

- The relationship of the top blade to the work piece never changes.
- Straight line cutting action
- Due to the rigidity of our system you can shear a very wide range of material with a single blade setting.
- Because of the reliability of our guillotine drive, we are able to provide our unmatched 5 year parts warranty.

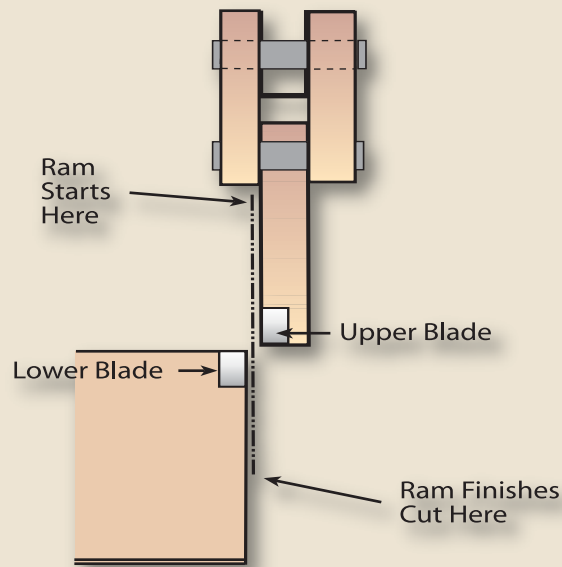

- Incredibly heavy duty gibbs control left to right and front to back forces to keep ram in a straight line giving the most precise cut.
- With our guillotine drive, the angle of the cut is consistent throughout the stroke.

Swingbeam/Rocker Arm Drive System

- If the ram pivots from the end frames, an arc or “swing” is created throughout the stroke.
- Due to their weaker drive system, swingbeams must adjust their blade gap for virtually every material thickness.
- Because the swingbeams pivot points are fixed, they cannot have variable rake adjustments.

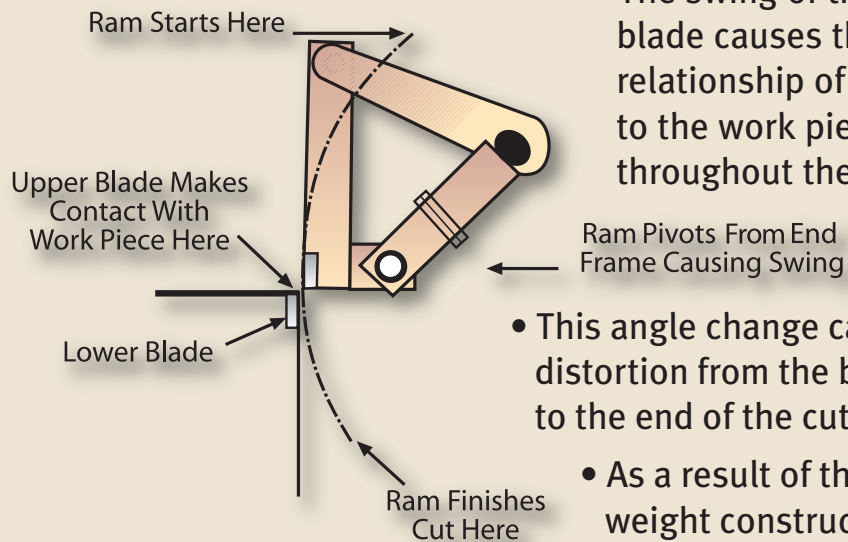

- The swing of the upper blade causes the angle or relationship of the top blade to the work piece to change throughout the stroke.
- This angle change causes distortion from the beginning to the end of the cut.
- As a result of their lighter weight construction and less rigid drive system, swingbeams typically only have a 1-2 year warranty.

Standard Features

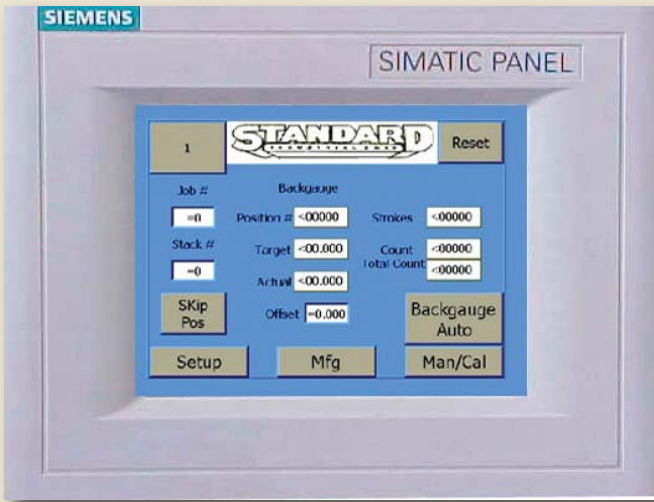

PLC Touch Screen Control

- Simple Go-To function
- 50 job programmability with 5 cut lengths per job
- Automatic actuation of backstop during program
- 5 programmable cut lengths per job
- Stack your jobs up to any number of strokes
- Inch/Metric conversion and Stroke Counter
- Programmable X (backstop) retract
- 2 year PLC and interface warranty
- Manual and programmable functions
- Swiveling pendant mount for easy operation

36" or 48" Travel **EXTREMELY Heavy Duty Backgauge**



No other backgauge comes close to the rigidity coupled with the brute strength of the Standard Industrial shear backgauge. Perfectly built for precision and outright ability to take abuse.

- Equipped with a manual easy swingaway backstop
- Available with optional power swingaway backstop
- Clear area under backgauge for support equipment
- +/- .005" backstop repeatability
- 5 Year parts warranty
- Complete O.S.H.A. compliance
- The absolute heaviest backgauge on the market

For 100% *U.S. Productivity*

Infinitely Variable Quick-Change Blade Gap Adjustment

All Standard shears come equipped with our positive drive, mechanical, quick-change blade gap adjustment. The AS250-6 up through the AS375-12 models are equipped with our ***Infinitely Variable*** side adjustable manual system.

The 14' and longer and all ½" and larger shears are equipped with the ***Infinitely Variable*** front operated ***Power*** blade gap system. Uniform and precision movement along machined tapered gibbs allows you to zero in on an exact precision cut.

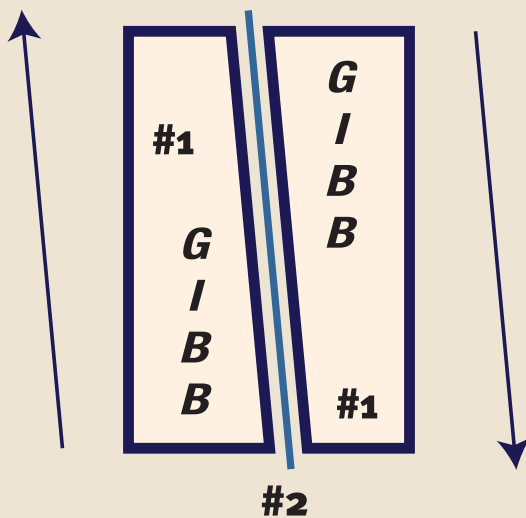

On each end of the shear ram is our ***Extremely Heavy-Duty*** Gibbing system. This positive mechanical system provides a smooth, uniform gap adjustment via precision machined tapered gibbs. Each gibb plate (#1) slides opposite of each other on oil impregnated nylon called Nylatron (#2). This Nylatron insures no excessive heat or friction is built up. These gibbs also control the front to back and left to right forces of the ram travel delivering the most precision cut available on any shear.

Fully Loaded, Extremely Heavy Duty Table

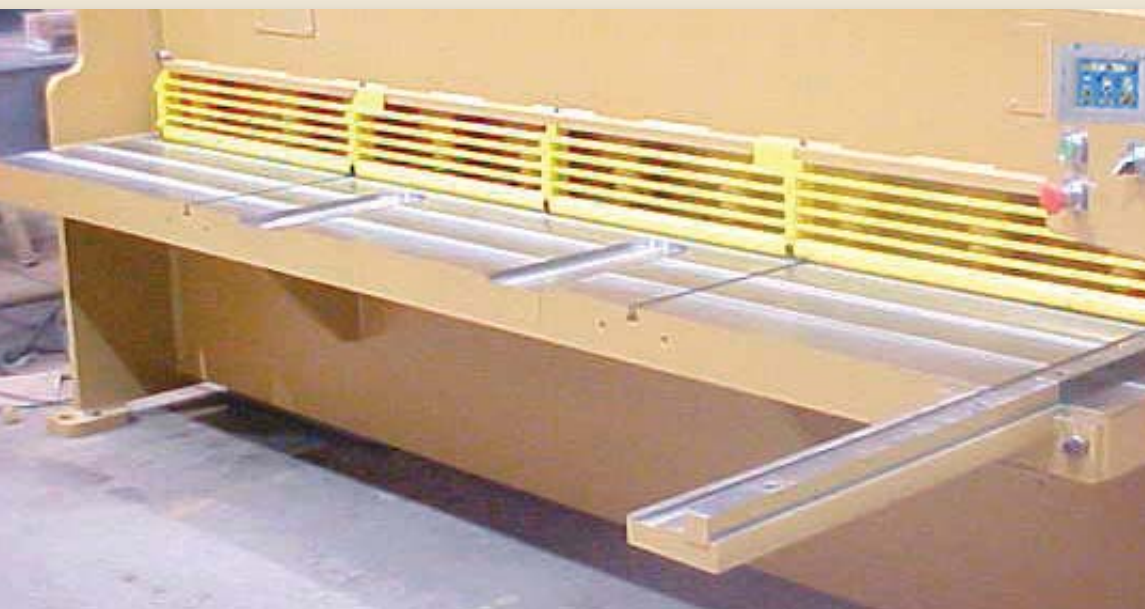

Each shear comes standard with an incredibly heavy duty , precision machined table. Each machine is equipped with multiple large hand slots for easy part handling. Plus t-slots for setting stops and front gauging. Also included is a 4' squaring arm (2' off table on right side) with a precision inlaid scale.



Model AS250-6 (1/4" x 6')

AS250-6 through AS250-10 AS375-6 through AS375-10

- 4' squaring arm with imbedded scale
- (2) hand slots in table
- (2) t-slots in table
- 36" travel, PLC controlled backgauge
- Manual, side adjustable, quick-change blade gap adjustment

AS250-12 and AS375-12



Model AS375-12 (3/8" x 12')

- 4' squaring arm with imbedded scale
- (3) hand slots in table
- (2) t-slots in table
- 36" travel, PLC controlled backgauge
- Manual, side adjustable, quick-change blade gap adjustment

Model AS375-12 (3/8" x 12') shown with optional left hand squaring arm, ball transfers and (3) 24" t-slot support arms



All 1/4" and 3/8" shears that are 12' and shorter come standard with a manual side adjustable gap adjustment.

For 100% *U.S. Capability*

AS250-14 through AS375-20 AS500-6 through AS500-20

- 4' squaring arm with imbedded scale
- Hand slots in table
- (2) t-slots in table
- 36" travel, PLC controlled backgauge
- POWER, FRONT OPERATED INFINITELY ADJUSTABLE, quick-change blade gap adjustment
- Heavy duty ball transfers mounted in table



Model AS500-12 (1/2" x 12')

All 1/2" and larger and 14' and longer shears are equipped with heavy duty ball transfers mounted in the table

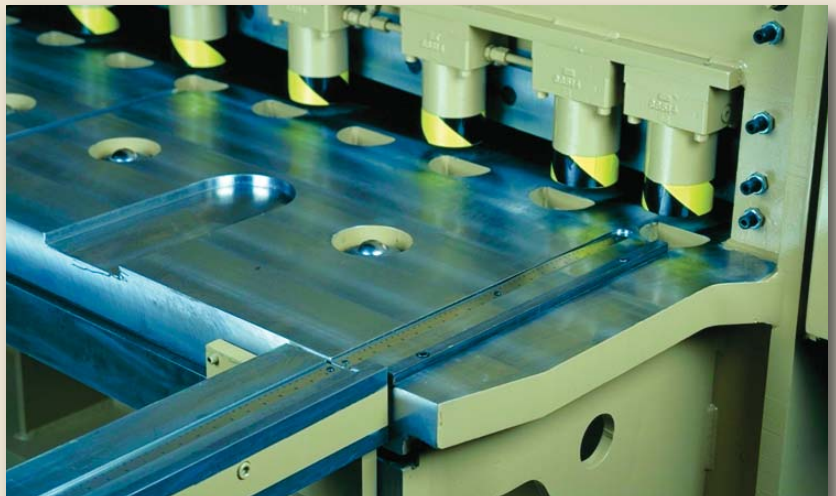

AS625-6 through AS1250-20

- 4' squaring arm with imbedded scale
- Hand slots in table
- (2) t-slots in table
- 48" travel, PLC controlled backgauge
- POWER, FRONT OPERATED INFINITELY ADJUSTABLE, quick-change blade gap adjustment
- Heavy duty ball transfers mounted in table



For 100% ***U.S. Precision***

How It Works

**Full
Even
Tonnage**

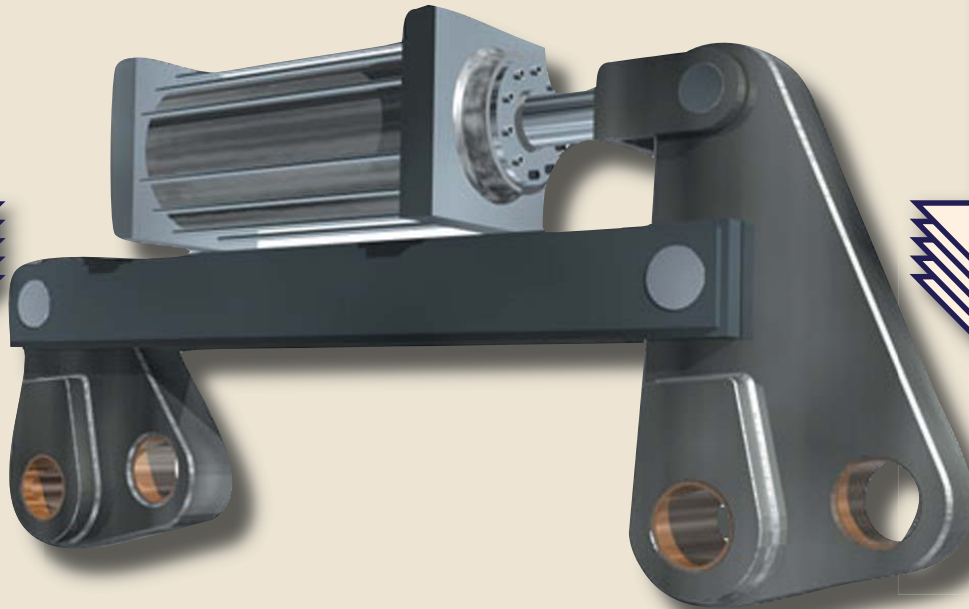

**Full
Even
Tonnage**

**Full Even Tonnage Throughout
Stroke and the Entire Length
of the Shear**

The single cylinder horizontal cylinder creates full tonnage via the massive bellcrank linkage system. Powered by just one cylinder, the bellcrank linkage supplies full tonnage the entire length of the shear. On each end of the shear ram is our incredibly heavy-duty and precision-machined tapered gibb system. This gibb system controls all front to back and left to right forces to provide the most precision cut available.

With only one cylinder you do not have to worry about “balancing” two cylinders and creating un-even tonnage and distortion in the cut. One cylinder creates full tonnage the entire cut instead of multiple cylinders creating various amounts of force.

OPTIONAL FEATURES

Table Options

Squaring Arms – (4' on right hand side is standard) – Optional 8' (6' off table) or 12' (10' off table) or additional 4' (2' off table) available on either left (high end of rake) and/or right hand side of shear.

Swing Stops For Squaring Arms – Quick-change, flip up/down stops that slide the length of the squaring arm for front gauging, repetitive work.

Disappearing/Gravity Stops for T-Slots – Stops that allow work piece to slide over the top but not backwards. These stops slide in table t-slots or in the optional support arms.



Above table shown with t-slot across front edge, Protractor in t-slot and ball transfers in table



Support Arms – Heavy duty, t-slotted arms mounted in line with standard table t-slots. Also able to slide left to right across front edge of shear table with optional t-slot. Available in 24", 36" and 48" and with optional imbedded scales and mounted ball transfers.

T-Slot Across Front Edge of Table – Slot for sliding support arms left to right.

Ball Transfers in Table – Heavy duty, rolling transfers mounted in holes in table to aid with material handling. Standard on most machines except for 1/4" and 3/8" shears that are 12' and shorter.

Additional T-Slots in Table – 2 are standard on all shears but more are available.

Additional Hand Slots in Table – 2 or 3 are standard depending on length but more are available.

Protractor – Used primarily for angle shearing, this unit can be mounted in the t-slots in the table.

Full Nylatron Table Cover – (pictured above) Fully covered table for complete protection of material, typically used in conjunction with hold down cylinders with nylatron impact pads.

For 100% *U.S. Innovation*

Backgauge Options

48" travel in lieu of 36" – For ½" and smaller shears. All 5/8" and larger shears are equipped with a 48" travel gauge.

Automatic Power Swing-Away Backgauge – All shears are equipped with a manual swing-away backstop. This option comes with 48" of travel and automatically swings the entire backgauge up and out of the way for longer material pass through.

High Speed Hydraulic System

All shears are available with high speed systems. Contact factory for more information.

Hold Down Cylinder Options

Impact Pads for Hold Down Cylinders – Heavy duty nylatron caps for all hold down cylinders to reduce marring of sensitive material.

Additional Hold Downs – Add an additional hold down on left hand side of shear for small piece work. Working on both sides of shear also prolongs blade life.

Independent Activation of Hold Downs – This option allows operator to actuate hold downs without actuating the ram/blade.

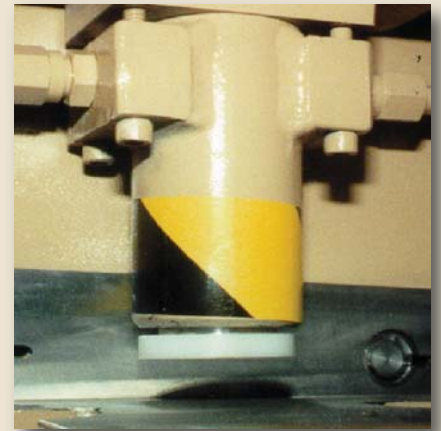

Automatic Lubrication System

Air operated, timed system that automatically brings grease to all lubrication points (except backgauge screws).

OPTIONAL FEATURES

Productivity Options

2 Position Power Rake Adjustment – This feature gives the shear (2) different rake angles to allow the most precision cutting in a wide range of capacities. Great for slitting when a flatter rake is needed.

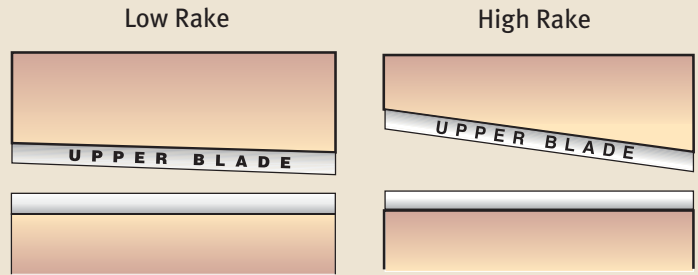

2 position power rake adjustment for slitting and other applications

Infinitely Variable Power Blade Gap Adjustment – (standard on all 14' and longer and ½" and larger shears) Precision, instantaneous push button blade gap control with non-computerized mechanical pointer showing exact blade gap position. Positive mechanical lead screws drive tapered gibbs providing infinite adjustment.

Paint Color

Choose from the standard Charcoal Grey or Beige for no additional charge or optionally choose any single color of your choice – customer must supply sample.

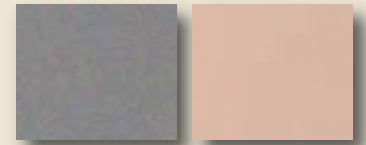

Shear Blades

Shock resistant industry standard blades come with all shears. Optional high carbon- high chrome blades are available – recommended for customers who use stainless 75% or more.

Oil Cooler

Air cooled heat reduction unit. Great for multiple shift operations and warmer climates. These coolers are standard with all high speed systems.

Material Handling Systems

Conveyors – Conveyance system used in conjunction with sheet support system used to remove material from under backgauge area.

Stacker – Final stage of Material Handling System. Stacks material conveyed from under shear.

Pneumatic Sheet Supports – Air actuated support system arms with rollers that rise and lower with the actuation of the ram. Used for material up to 1/2" plate.

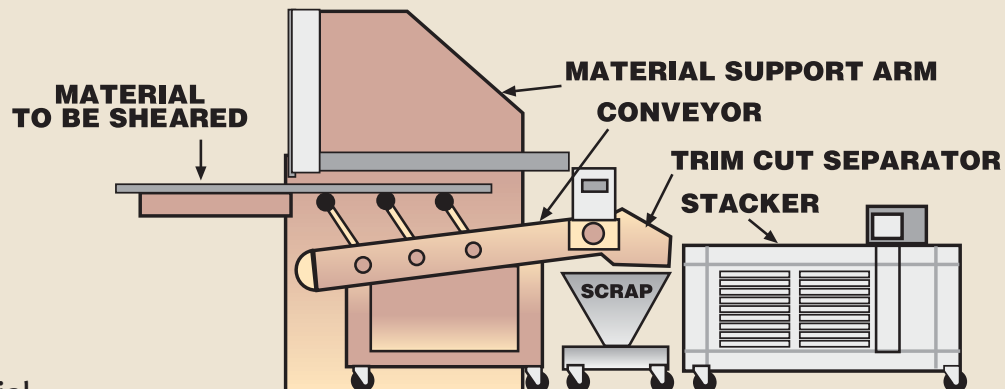

7 Year Extended Warranty Service

Only available from Standard Industrial Corp. is our unmatched Extended Warranty that substantially lengthens the existing 5 Year parts warranty but also provides a one year limited onsite labor warranty. This package includes:

- ◆ A 7 year parts warranty in lieu of standard 5 year parts warranty
- ◆ A 2 year PLC and CNC warranty
- ◆ A 1 year onsite limited labor warranty

In the event of a problem the customer will be required to help troubleshoot over the phone. If the problem cannot be diagnosed and troubleshooting has been exhausted, Standard will send in a technician at no charge to resolve the situation.

Onsite Training

Onsite training is not included or required due to the simplicity of our machinery however it is available if needed.

Safety Systems

Light Curtain Safety Barriers – Infra-red light curtains that can be used in lieu of or in conjunction with standard OSHA approved awareness barrier. These curtains can also be placed on back of shear to enclose backgauge area.

Physical Barriers/Cages – Physical barriers completely enclosing backgauge area. An interlocking gate that shuts the machine down when open is included.

Compliance Options – U.L. Listing and CSA compliance options are available.

CNC Square Gauge Systems

State of the art, 100% U.S. Made CNC front gauging system for all Standard Industrial shears. These extremely heavy duty systems can be supplied with up to 6', 10' and 12' arms.

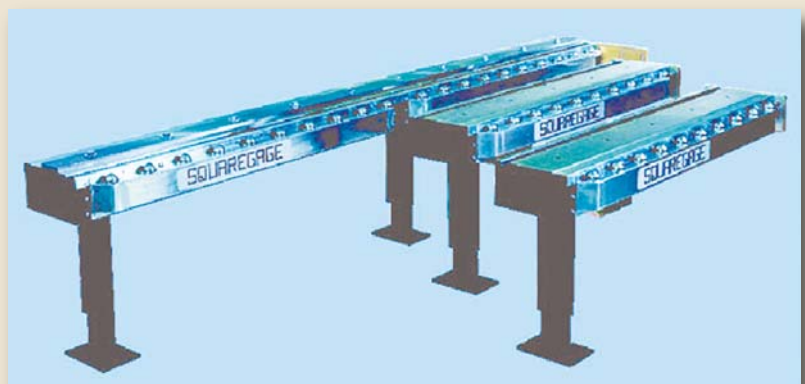
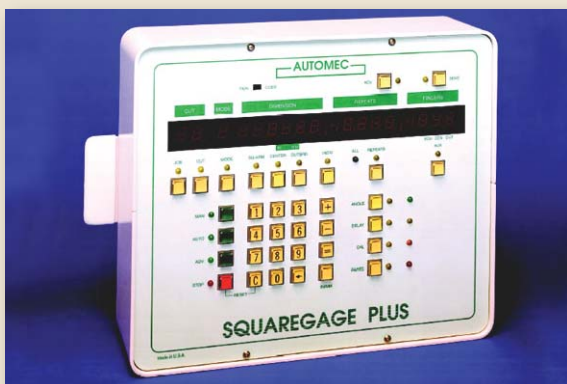

Components you know Parts you can find People you can talk to



Vickers Hydraulics



Sun Cartridge Valves



Siemens Electric Components



Baldor and Lincoln Motors



**Readily available
off-the-shelf
seal kits and
fittings**